

SDM-P82

SERVICE MANUAL

US Model
Canadian Model

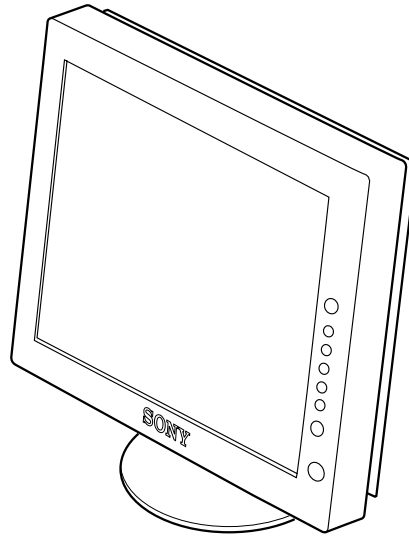

SPECIFICATIONS

LCD panel	Panel type: a-Si TFT Active Matrix	Dimensions (width/height/depth)
Input signal format	Picture size: 18.1 inch RGB operating frequency* Horizontal: 28 – 92 kHz Vertical: 56 – 85 Hz	Display (upright): Approx. 404 × 406 × 201 mm (16 × 16 × 8 inches) (with stand)
Resolution	Horizontal: Max. 1280 dots Vertical: Max. 1024 lines	Approx. 404 × 332.6 × 86.2 mm (16 × 13 1/8 × 3 1/2 inches) (without stand)
Input signal levels	Analog RGB video signal 0.7 Vp-p, 75 Ω, positive SYNC signal TTL level, 2.2 kΩ, positive or negative (Separate horizontal and vertical, or composite sync) 0.3 Vp-p, 75Ω, negative (Sync on green)	Mass Approx. 7.6 kg (16 lb 12 oz) (with stand) Approx. 6.3 kg (13 lb 14 oz) (without stand)
Power requirements	Digital RGB (DVI) signal: TMDS (Single link) 100 – 240 V, 50 – 60 Hz, Max. 1.2 A	Plug & Play DDC2B
Power consumption	Max. 58 W	
Operating temperature	5 – 35 °C	

- * Recommended horizontal and vertical timing condition
- Horizontal sync width duty should be more than 4.8% of total horizontal time or 0.8 μs, whichever is larger.
 - Horizontal blanking width should be more than 2.5 μsec.
 - Vertical blanking width should be more than 450 μsec.

Design and specifications are subject to change without notice.

TFT LCD Color Computer Display
SONY®

SAFETY CHECK-OUT

After correcting the original service problem, perform the following safety checks before releasing the set to the customer:

1. Check the area of your repair for unsoldered or poorly-soldered connections. Check the entire board surface for solder splashes and bridges.
2. Check the interboard wiring to ensure that no wires are “pinched” or contact high-wattage resistors.
3. Check that all control knobs, shields, covers, ground straps, and mounting hardware have been replaced. Be absolutely certain that you have replaced all the insulators.
4. Look for unauthorized replacement parts, particularly transistors, that were installed during a previous repair. Point them out to the customer and recommend their replacement.
5. Look for parts which, though functioning, show obvious signs of deterioration. Point them out to the customer and recommend their replacement.
6. Check the line cords for cracks and abrasion. Recommend the replacement of any such line cord to the customer.
7. Check the connector shell, metal trim, “metallized” knobs, screws, and all other exposed metal parts for AC Leakage. Check leakage as described right.

LEAKAGE TEST

The AC leakage from any exposed metal part to earth ground and from all exposed metal parts to any exposed metal part having a return to chassis, must not exceed 0.5 mA (500 microamperes).

Leakage current can be measured by any one of three methods.

1. A commercial leakage tester, such as the Simpson 229 or RCA WT-540A. Follow the manufacturers’ instructions to use these instruments.
2. A battery-operated AC milliammeter. The Data Precision 245 digital multimeter is suitable for this job.
3. Measuring the voltage drop across a resistor by means of a VOM or battery-operated AC voltmeter. The “limit” indication is 0.75 V, so analog meters must have an accurate low-voltage scale. The Simpson 250 and Sanwa SH-63Trd are examples of a passive VOMs that are suitable. Nearly all battery operated digital multimeters that have a 2 V AC range are suitable. (See Fig. A)

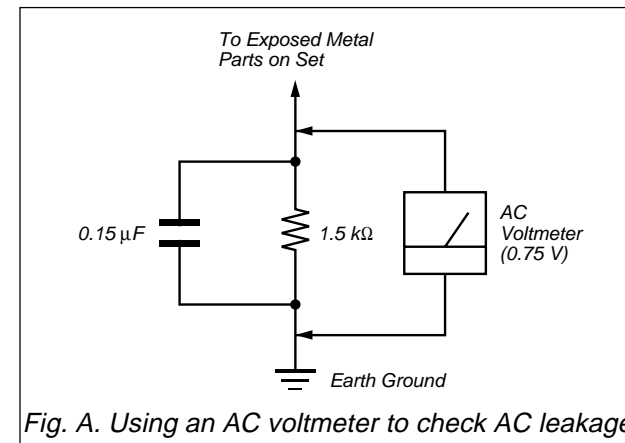

Fig. A. Using an AC voltmeter to check AC leakage.

WARNING!!

SAFETY-RELATED COMPONENT WARNING!!
COMPONENTS IDENTIFIED BY SHADING AND MARK \triangle ON THE SCHEMATIC DIAGRAMS, EXPLODED VIEWS AND IN THE PARTS LIST ARE CRITICAL FOR SAFE OPERATION. REPLACE THESE COMPONENTS WITH SONY PARTS WHOSE PART NUMBERS APPEAR AS SHOWN IN THIS MANUAL OR IN SUPPLEMENTS PUBLISHED BY SONY. CIRCUIT ADJUSTMENTS THAT ARE CRITICAL FOR SAFE OPERATION ARE IDENTIFIED IN THIS MANUAL. FOLLOW THESE PROCEDURES WHENEVER CRITICAL COMPONENTS ARE REPLACED OR IMPROPER OPERATION IS SUSPECTED.

AVERTISSEMENT!!

ATTENTION AUX COMPOSANTS RELATIFS À LA SÉCURITÉ!!
LES COMPOSANTS IDENTIFIÉS PAR UNE TRAME ET UNE MARQUE \triangle SONT CRITIQUES POUR LA SÉCURITÉ. NE LES REMPLACER QUE PAR UNE PIÈCE PORTANT LE NUMÉRO SPECIFIÉ. LES RÉGLAGES DE CIRCUIT DONT L'IMPORTANCE EST CRITIQUE POUR LA SÉCURITÉ DU FONCTIONNEMENT SONT IDENTIFIÉS DANS LE PRÉSENT MANUEL. SUIVRE CES PROCÉDURES LORS DE CHAQUE REMPLACEMENT DE COMPOSANTS CRITIQUES, OU LORSQU'UN MAUVAIS FONCTIONNEMENT EST SUSPECTÉ.

POWER SAVING FUNCTION

This monitor meets the power-saving guidelines set by VESA, ENERGY STAR, and NUTEK. If the monitor is connected to a computer or video graphics board that is DPMS (Display Power Management Signaling) compliant, the monitor will automatically reduce power consumption as shown below.

Power mode	Power consumption	(power) indicator
normal operation	58 W (max.)	green
active off* (deep sleep)**	3 W (max.)	orange
(power) off	1 W	red
main power off	0 W	off

* When your computer enters the “active off” mode, the input signal is cut and NO INPUT SIGNAL appears on the screen. After 10 seconds, the monitor enters the power saving mode.

** “Deep sleep” is a power saving mode defined by the Environmental Protection Agency.

Note

If the  (POWER SAVE) is set to OFF (page 16), the monitor does not enter the power saving mode.

AUTOMATIC PICTURE QUALITY ADJUSTMENT FUNCTION

(ANALOG RGB)

When the monitor receives an input signal, it automatically adjusts the picture’s position and sharpness (phase/pitch), and ensures that a clear picture appears on the screen.

The factory preset mode

When the monitor receives an input signal, it automatically matches the signal to one of the factory preset modes stored in the monitor’s memory to provide a high quality picture at the center of the screen. If the input signal matches the factory preset mode, the picture is appears on the screen automatically with the appropriate default adjustment.

If input signals do not match one of the factory preset modes

When the monitor receives an input signal, the automatic picture quality adjustment function of this monitor is activated and ensures that a clear picture always appears on the screen (within the following monitor frequency ranges):

Horizontal frequency: 28 – 92 kHz

Vertical frequency: 56 – 85Hz

Consequently, the first time the monitor receives input signals that do not match one of the factory preset modes, the monitor may take a longer time than normal for displaying the picture on the screen. This adjustment data is automatically stored in memory so that next time, the monitor will function in the same way as when the monitor receives the signals that match one of the factory preset modes.

If you adjust the phase, pitch, and pictures position manually

For some input signals, the automatic picture quality adjustment function of this monitor may not completely adjust the picture position, phase, and pitch. In this case, you can manually set these adjustments (page 12). If you manually set these adjustments, they are stored in memory as user modes and automatically recalled whenever the monitor receives the same input signals.

TABLE OF CONTENTS

<u>Section</u>	<u>Title</u>	<u>Page</u>	<u>Section</u>	<u>Title</u>	<u>Page</u>
1. DISASSEMBLY			3. DIAGRAMS		
1-1.	Rear Cover and Cabinet Assy Removal	1-1	3-1.	Block Diagrams	3-1
1-2.	I Board Removal	1-2	3-2.	Circuit Boards Location	3-2
1-3.	G Board Removal	1-3	3-3.	Schematic Diagrams and Printed Wiring Boards..	3-2
1-4.	A Board Removal	1-4		(1)Schematic Diagram	
1-5.	LCD Unitl Removal	1-5		of A(a , b , c , d , e , f , g) Board.	3-4
1-6.	LCD Panel Removal	1-6		(2)Schematic Diagram of H Board.	3-12
1-7.	H Board Removal	1-7		(3)Schematic Diagram of I Board.	3-14
				(4)Schematic Diagram of G Board.	3-16
2. ADJUSTMENTS			4. EXPLODED VIEWS		
2-1.	Service Functions of Buttons in Front Panel	2-1	4-1.	Chassis	4-2
2-2.	Usea of Service Mode	2-2	4-2.	Packing Materials	4-3
2-3.	Functions of Service Mode	2-3			
2-4.	White Balance Adjustment	2-3			
2-5.	Action after Replacing				
	the LCD Panel and Board	2-5			
			5. ELECTRICAL PARTS LIST		
					5-1

SECTION 1 DISASSEMBLY

1-1. REAR COVER AND CABINET ASSY REMOVAL

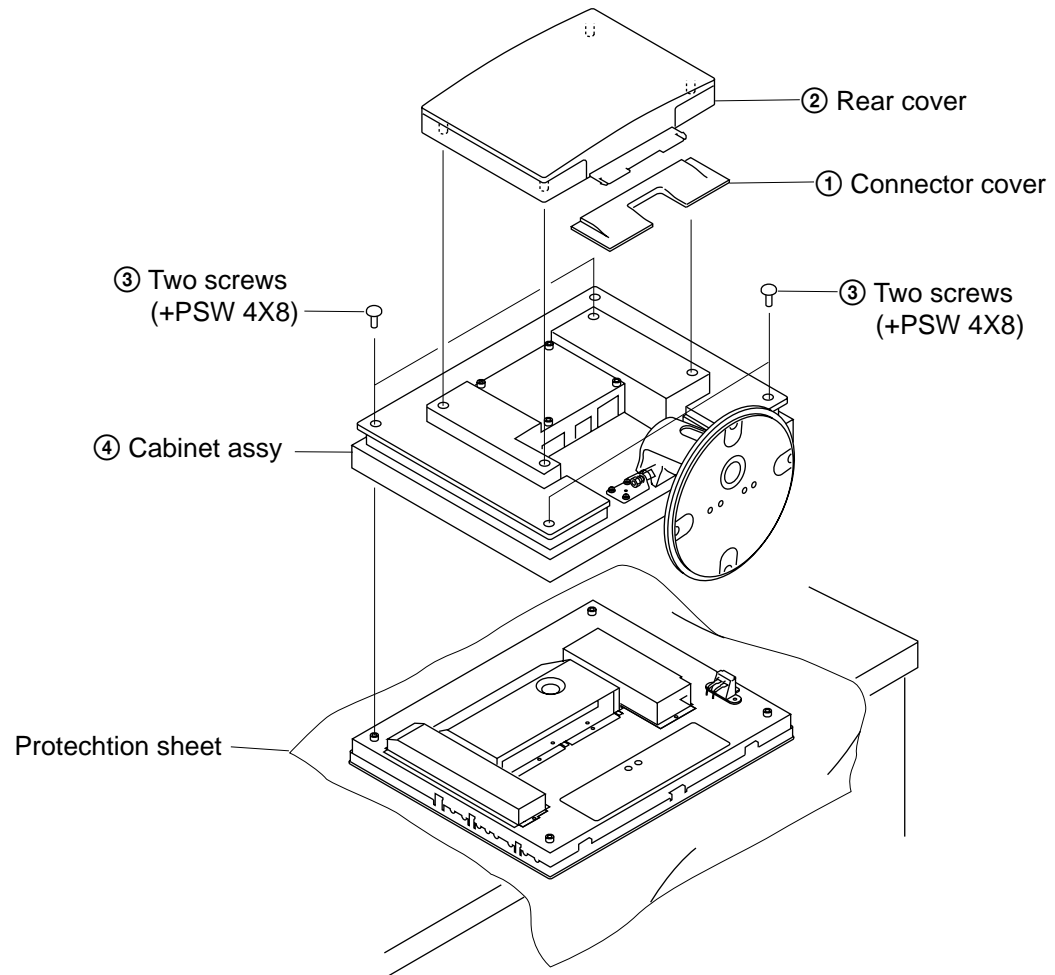

1-2. I BOARD REMOVAL

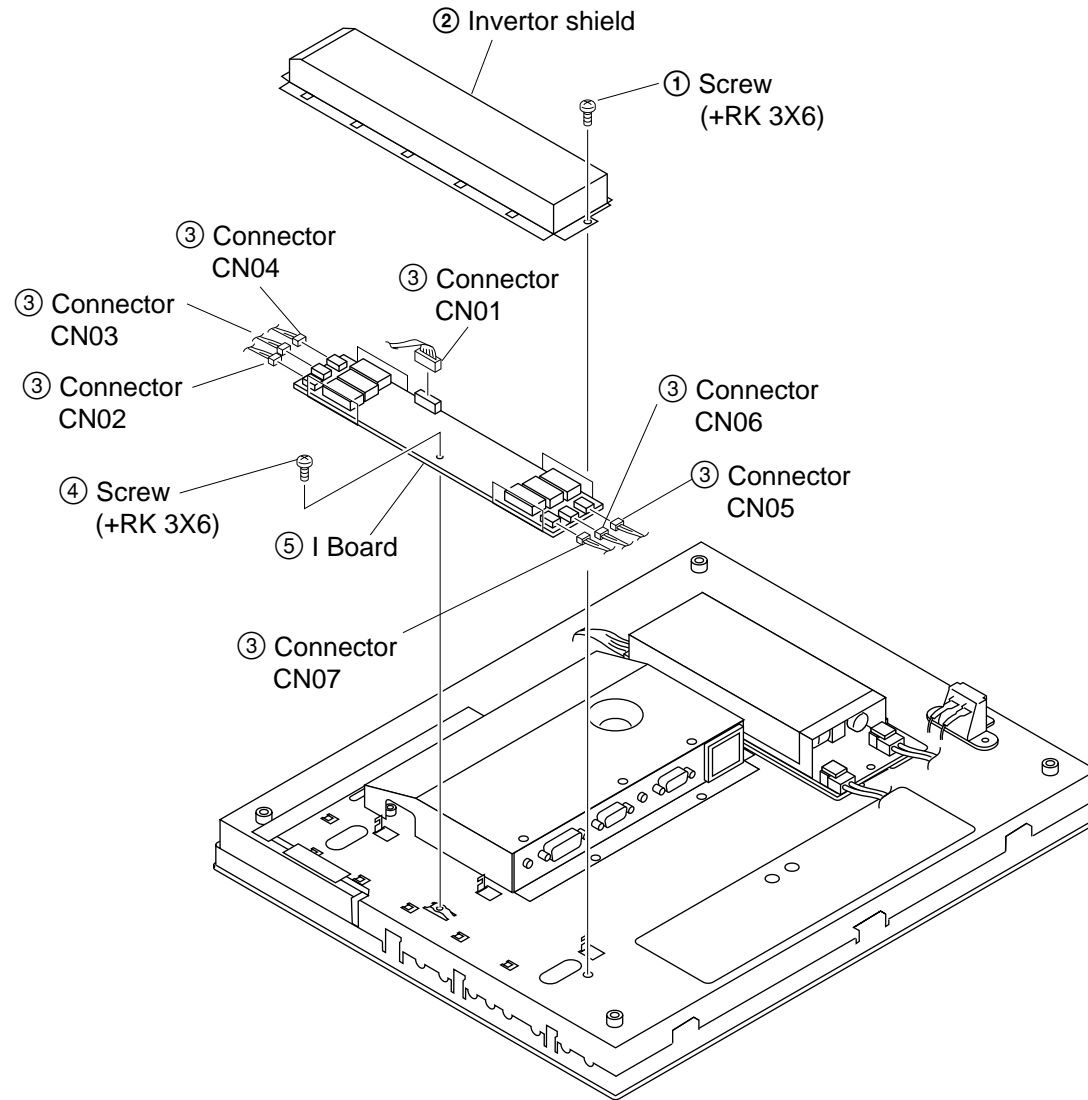

1-3. G BOARD REMOVAL

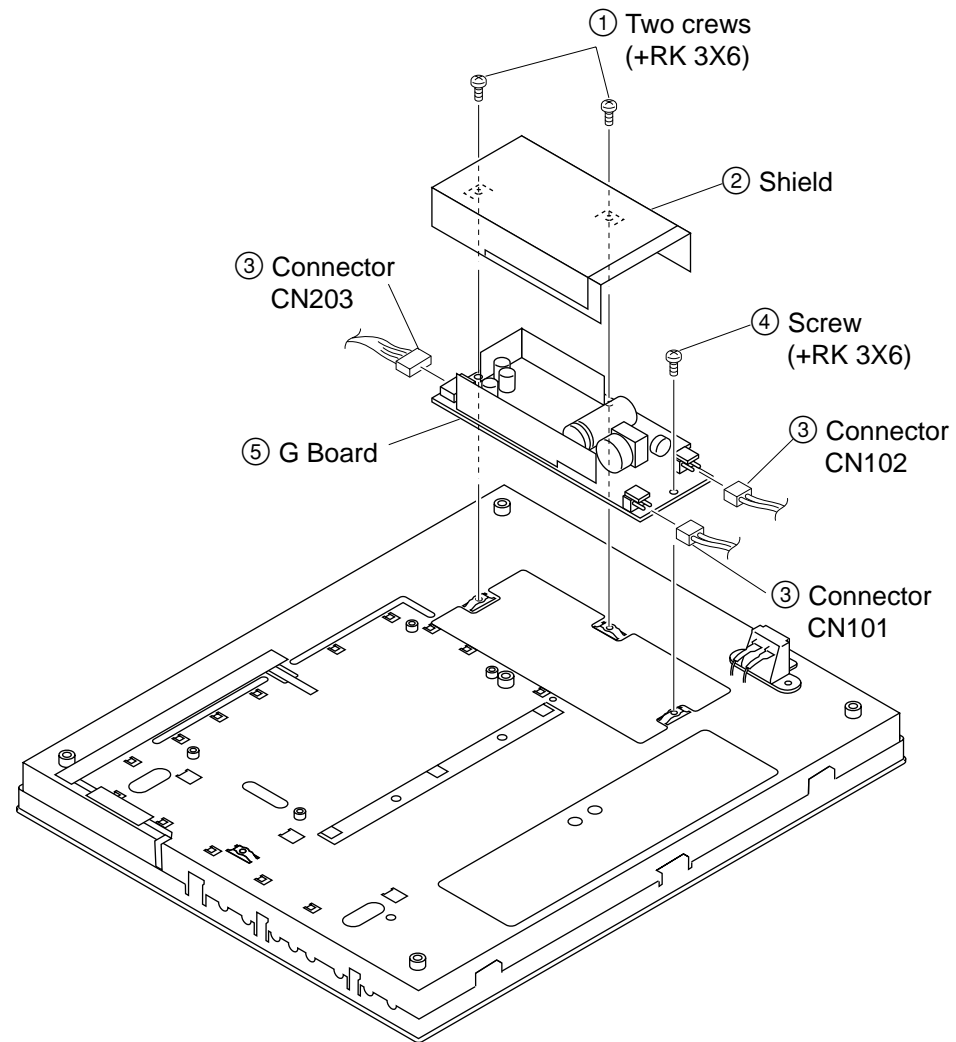

1-4. A BOARD REMOVAL

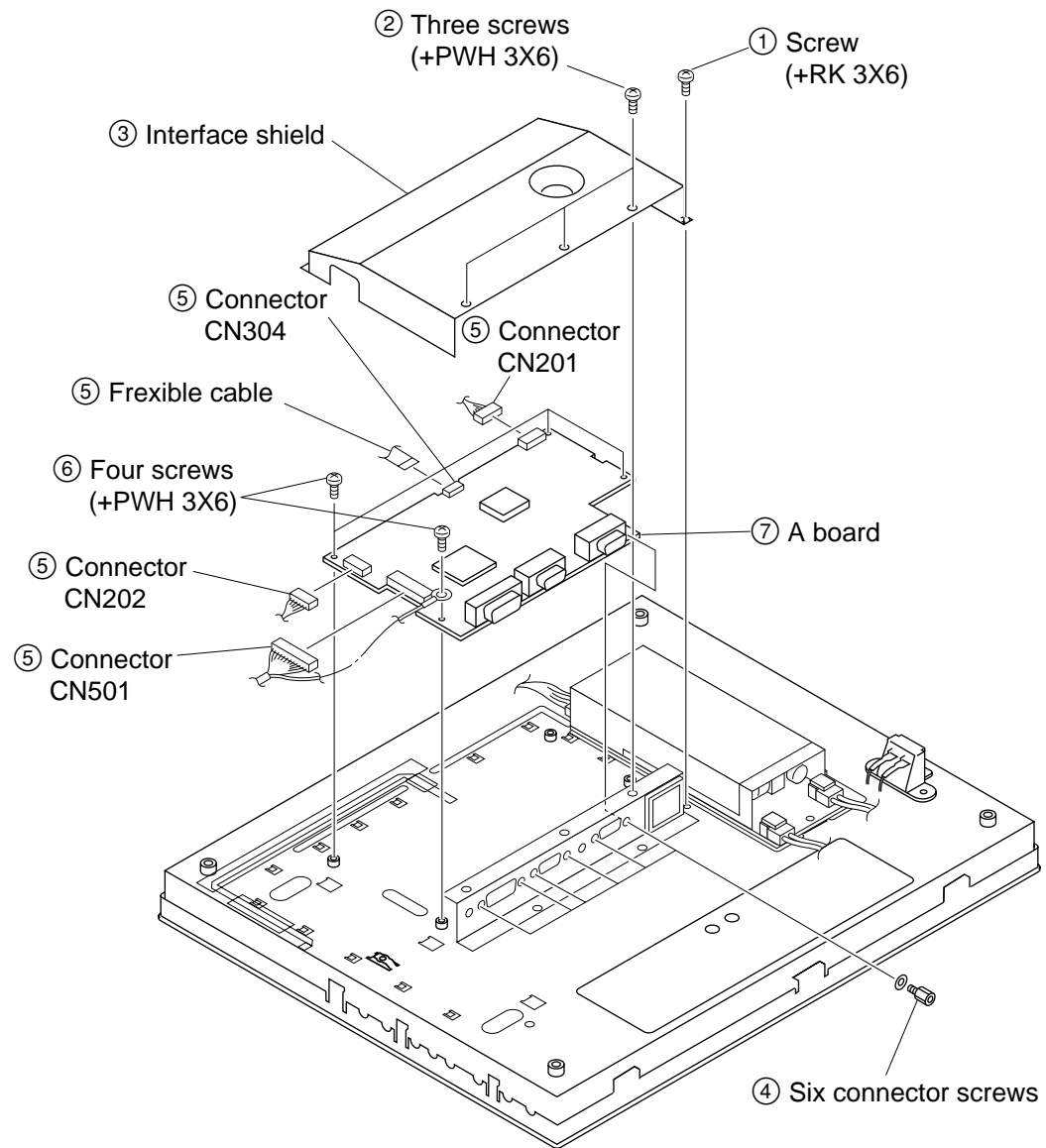

1-5. LCD UNIT REMOVAL

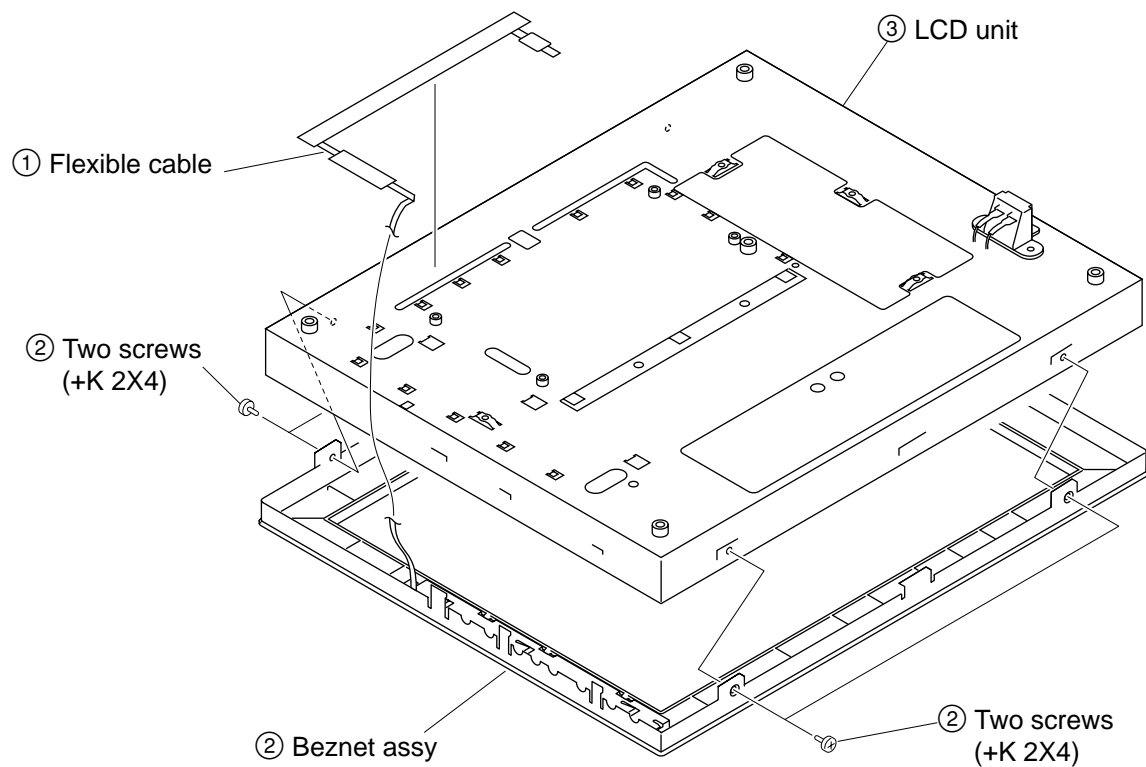

1-6. LCD PANEL REMOVAL

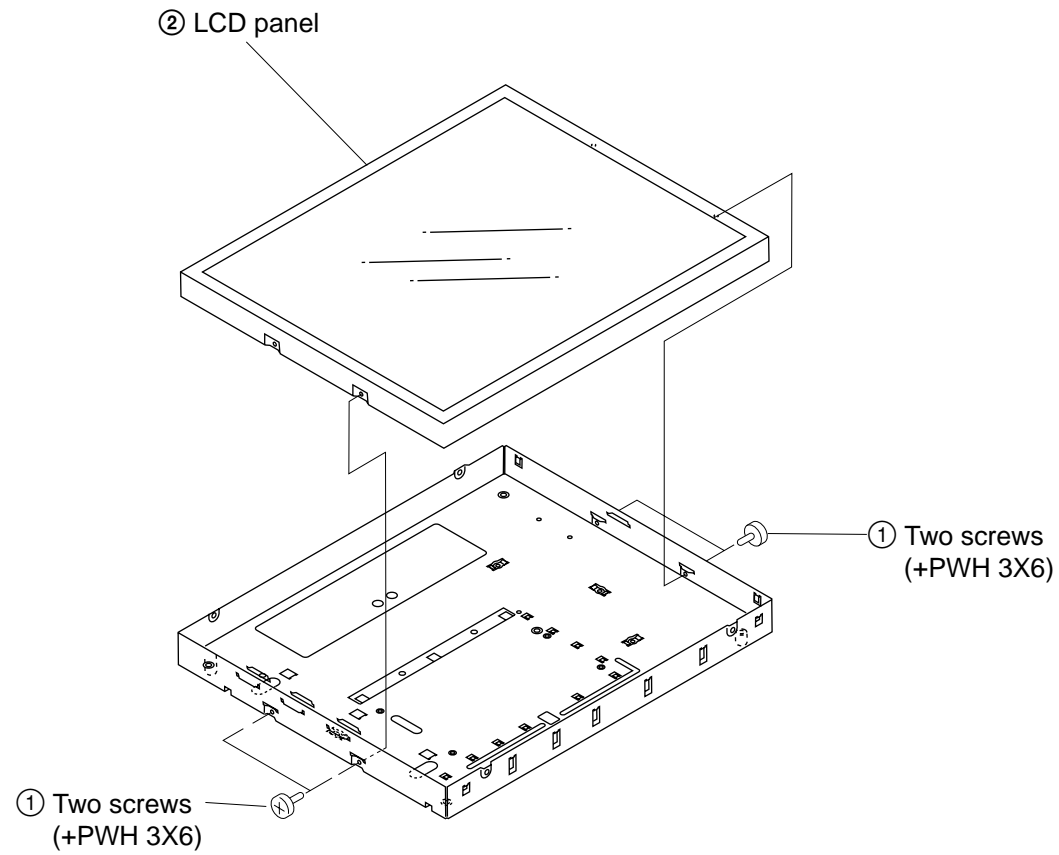

1-7. H BOARD REMOVAL

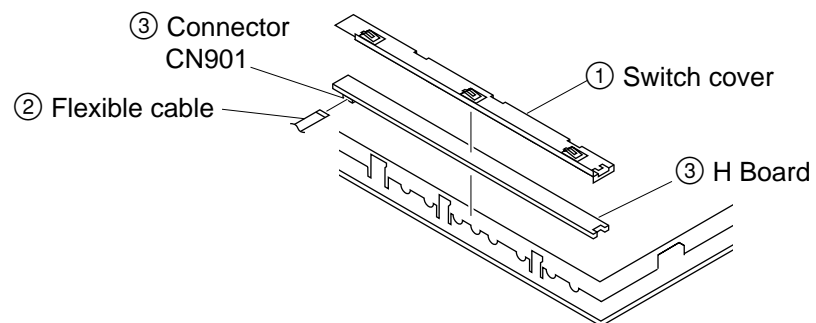

SECTION 2 ADJUSTMENTS

2-1. Service Functions of Buttons in Front Panel

The following functions are available for servicing the set.

1. **To display the model information**
Press the MENU button for five seconds or more in the ordinary power-on state, and the following information is displayed on the screen:
 - Model name
 - Serial number
 - Manufactured year and weekThis function is described in the instruction manual also.
2. **To display ETI (Elapsed Time Indicator)**
Press the OK button for five seconds or more in the ordinary power-on state, and the cumulative power-on time excluding the power-off and power saving state is displayed on the screen.
3. **All mode recall**
Press the POWER button with pressing the OK button in the power-off state, and the user memory is completely cleared and the system is reset to the factory setting. This reset is similar to RESET in the OSD menu, but differs from it in the following:
 - The NO SYNC AGING flag is cleared.
 - LANGUAGE is set to ENGLIDH.
 - INPUT is set to INPUT1: DVI-D.
4. **To set the NO SYNC AGING flag**
Press the POWER button with pressing the UP (↑) button in the power-off state, and the NO SYNC AGING flag is set. In this setting, when the input with no input signal is selected, the system goes into the AGING MODE.
The NO SYNC AGING flag is held until it is cleared. To clear the NO SYNC AGING flag, go into the service mode and then set the AGING MODE to OFF, or execute the all mode recall.
5. **To enter the service mode**
Press the POWER button with pressing the UP (↑) and DOWN (↓) buttons in the power-off state, and the system is set to the service mode. The service mode will be explained later.
To exit from the service mode, turn off the power.
6. **To copy EDID to the EEPROM and to clear ETI**
Press the POWER button with pressing the UP (↑) and OK buttons in the power-off state, and the data for the model information are copied to the EEPROM for the internal microcontroller from EDID of INPUT2: HD15, and the model information display is made correct.
When replacing the A board, this operation is required after writing EDID and at the same time ETI is reset to 0.
7. **To enter the ISP mode**
Turn on the MAIN POWER switch with pressing the DOWN (↓) button in the main-power-off state, and the system enters the ISP mode. The POWER LED goes off, and both input LED's 1 and 2 light on, and the picture disappears, and any button becomes invalid.
In the ISP mode, the internal software can be updated with an external personal computer using a special fixture.
To cancel the ISP mode, turn off the MAIN POWER switch.

2-2. Uses of Service Mode

1. Turn off the power with the POWER button in the front panel. The red POWER LED lights on.
2. Press the POWER button in the front panel with pressing the UP (↑) and DOWN (↓) buttons, and the system enters the service mode.
When no signal is input to the selected input terminal, the following functions are disabled.
3. Press the MENU button, and the main menu is displayed. Then go to page 2 of the main menu with the UP (↑) or DOWN (↓) button, then select the MAINTAIN icon on the bottom line, and then press the OK button.
4. In this menu screen, the version number and released date of the internal software can be checked.
5. The structure of the MAINTAIN menu is shown below.

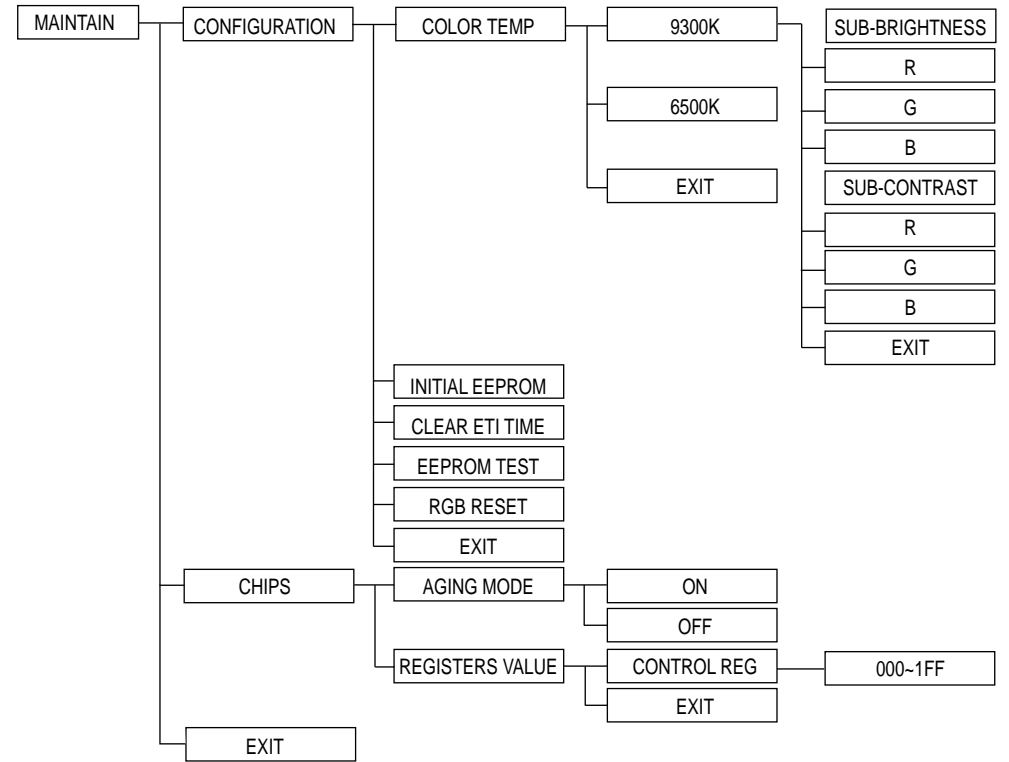

The operation procedure is basically same as that of the ordinary user controls. The function of each menu is explained in next section.

2-3. Functions of Service Mode

1. **COLOR TEMP**
This is used for the white balance adjustment at color temperature 9300 K and 6500 K. The adjustment requires to be done for every input (INPUT1: DVI-D, INPUT1: HD15, or INPUT2: HD15) by switching the input. The adjustment data is stored into the register for respective inputs.
2. **INITIAL EEPROM**
This sets the data of the EEPROM to the default data. This operation is not required usually.
3. **CLEAR ETI TIME**
This resets the ETI (Elapsed Time Indicator) counter to 00000 H.
4. **EEPROM TEST**
This tests writing and reading of the EEPROM.
5. **RGB RESET**
This adjust the offset and gain of the input AD converter for the analog inputs (INPUT1: HD15 and INPUT2:HD15). As these adjustments are common to both inputs, perform them for either input. It is unnecessary for another input. Execute the adjustments under the condition where the signal specified in "White Balance Adjustment" is input.
6. **AGING IN MODE**
This sets and clears the NO SYNC AGING flag.
AGING MODE = ON: Sets the NO SYNC AGING flag.
AGING MODE = OFF: Clears the NO SYNC AGING flag.
When the NO SYNC AGING flag is set and the input with no input signal is selected, the system goes into the AGING MODE. The NO SYNC AGING flag is held until it is cleared. To clear the NO SYNC AGING flag, go into the service mode and then set the AGINGN MODE to OFF, or execute the all mode recall.
7. **CONTROL REG.**
This can check the data of the internal registers. This operation is not required usually.

2-4. White Balance Adjustment

1. **Preparation**
 - (1) Measurement point : Center of screen
 - (2) Measurement distance : 50 cm
 - (3) Measurement angle : 90°
 - (4) Color analyzer (Minolta CS-1000 or equivalent)
 - (5) Signal generator (Astro Design VG-828D or equivalent)
Be sure to calibrate the analog RGB output level with 75Ω termination.
2. **Service mode setting**
Enter the service mode referring to step 1 and 2 of Section 2-2.
3. **Aging**
Set the AGING MODE in the service mode to ON. Disconnect the signal input terminal or select the input with no signal input, and the system goes into the AGING MODE.
Execute aging for 30 minutes or more.
4. **User control setting**
Feed a signal to the selected input, and then execute reset in the menu screen. Then, move the menu display position to avoid the measurement point. Or, set the following for respective inputs.

BACKLIGHT (Brightness of backlight) = 100
CONTRAST = 70
BRIGHTNESS = 50
Menu display position = not center of screen (Avoid the measurement point.)
(The setting of the menu display position is common to respective inputs.)
ECO = OFF (The setting of ECO is common to respective inputs.)

Do not change the above setting until the white balance adjustment is completed.

5. Analog RGB white balance adjustment

- (1) Feed the signal listed below to INPUT2: HD15, and then select INPUT2: HD15. Then execute RGB RESET in the service mode menu.

Signal timing	Pattern	Input level
VESA 1280 * 1024 / 60Hz	Gray scale	0.73 Vp-p

- (2) Feed the signal listed below to INPUT2: HD15.

Signal timing	Pattern	Pattern
VESA 1280 * 1024 / 60Hz	All gray	30 IRE (0.21 Vp-p)

- (3) Select COLOR TEMP → 9300K in the service mode menu, and set the data listed below as initial data for adjustment.

SUB-BRIGHTNESS			SUB-CONTRAST		
R	G	B	R	G	B
30	30	30	141	141	141

- (4) Adjust SUB-BRIGHTNESS: R, G, and B. Specifications are listed below.

x	y	Brightness (cd/m ²)
0.283 ± 0.003	0.298 ± 0.003	14 ± 0.7

- (5) Select COLOR TEMP → 6500K in the service mode menu, and set the data listed below as initial data for adjustment.

SUB-BRIGHTNESS			SUB-CONTRAST		
R	G	B	R	G	B
30	30	30	141	141	141

- (6) Adjust the SUB-BRIGHTNESS: R, G, and B. Specifications are listed below.

x	y	Brightness (cd/m ²)
0.313 ± 0.003	0.329 ± 0.003	14 ± 0.7

- (7) After adjusting (4) and (6), write down the value of SUB-CONTRAST and SUB-BRIGHTNESS.

- (8) Feed the signal to INPUT1: HD15, and then select INPUT1: HD15. Select COLOR TEMP → 9300K then 6500K in the service mode menu, and enter the value written down in step (7) respectively.

6. Digital RGB white balance adjustment

- (1) Feed the signal listed below to INPUT1: DVI-D.

Signal timing	Pattern	Input level
VESA 1280 * 1024 / 60Hz	All gray	30 IRE

- (2) Select COLOR TEMP → 9300K in the service mode menu, and set the data listed below as initial data for adjustment.

SUB-BRIGHTNESS			SUB-CONTRAST		
R	G	B	R	G	B
40	40	40	130	130	130

- (3) Adjust the SUB-BRIGHTNESS: R, G, and B. Specifications are listed below.

x	y	Brightness (cd/m ²)
0.283 ± 0.003	0.298 ± 0.003	14 ± 0.7

(4) Select COLOR TEMP → 6500K in the service mode menu, and set the data listed below as initial data for adjustment.

SUB-BRIGHTNESS			SUB-CONTRAST		
R	G	B	R	G	B
40	40	40	130	130	130

(5) Adjust the SUB-BRIGHTNESS: R, G, and B. Specifications are listed below.

x	y	Brightness (cd/m ²)
0.313 ± 0.003	0.329 ± 0.003	14 ± 0.7

7. Setting for shipping

Turn off the power with the POWER button in the front panel. Check that the red POWER LED lights on, and then execute the all mode recall. (press the POWER button with pressing the OK button in the power-off state)

2-5. Action after Replacing the LCD Panel and Board

1. After replacing the LCD panel
 - (1) White balance adjustment. (Refer to Section 2-4.)
 - (2) CLEAR ETI TIME. (Refer to Section 2-3 step 3.)
 - (3) Check of picture and sound.

2. After replacing the A board
 - (1) White balance adjustment. (Refer to Section 2-4.)
 - (2) EDID writing.

As the write protection is not applied in this unit, it is possible to write data with an ordinary writing fixture.
It is required to be written for INPUT1: DVI-D, INPUT1: HD15, and INPUT2: HD15 respectively.
Take care that the data for DVI-D and HD15 terminals are different from each other.
 - (3) EDID copy to the EEPROM and ETI clear. (Refer to Section 2-1 step 6.)
Be sure to perform them after EDID writing. After executing, check that the correct model information is displayed. (Refer to Section 2-1 step 1.)
 - (4) Operation check of buttons and LED's in the front panel, and Check of picture and sound for respective inputs.

3. After replacing the I board
 - (1) White balance adjustment. (Refer to Section 2-4.)
 - (2) Check of picture and sound.

4. After replacing the G board
 - (1) Operation check of the MAIN POWER switch.
 - (2) Check of picture and sound.

5. After replacing the H board
 - (1) Operation check of buttons and LED's in the front panel.

SECTION 3 DIAGRAMS

3-1. BLOCK DIAGRAMS

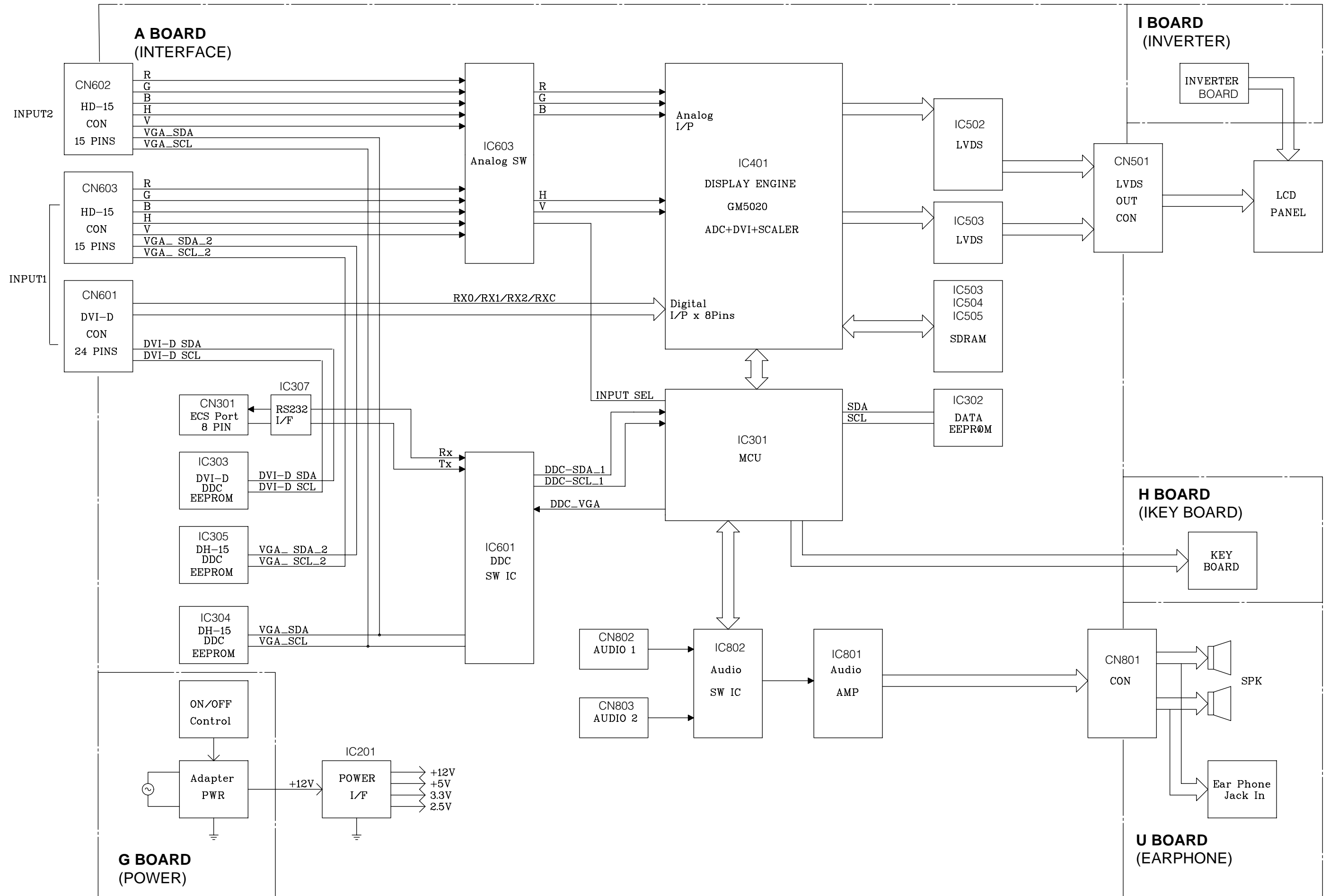

3-2. CIRCUIT BOARDS LOCATION

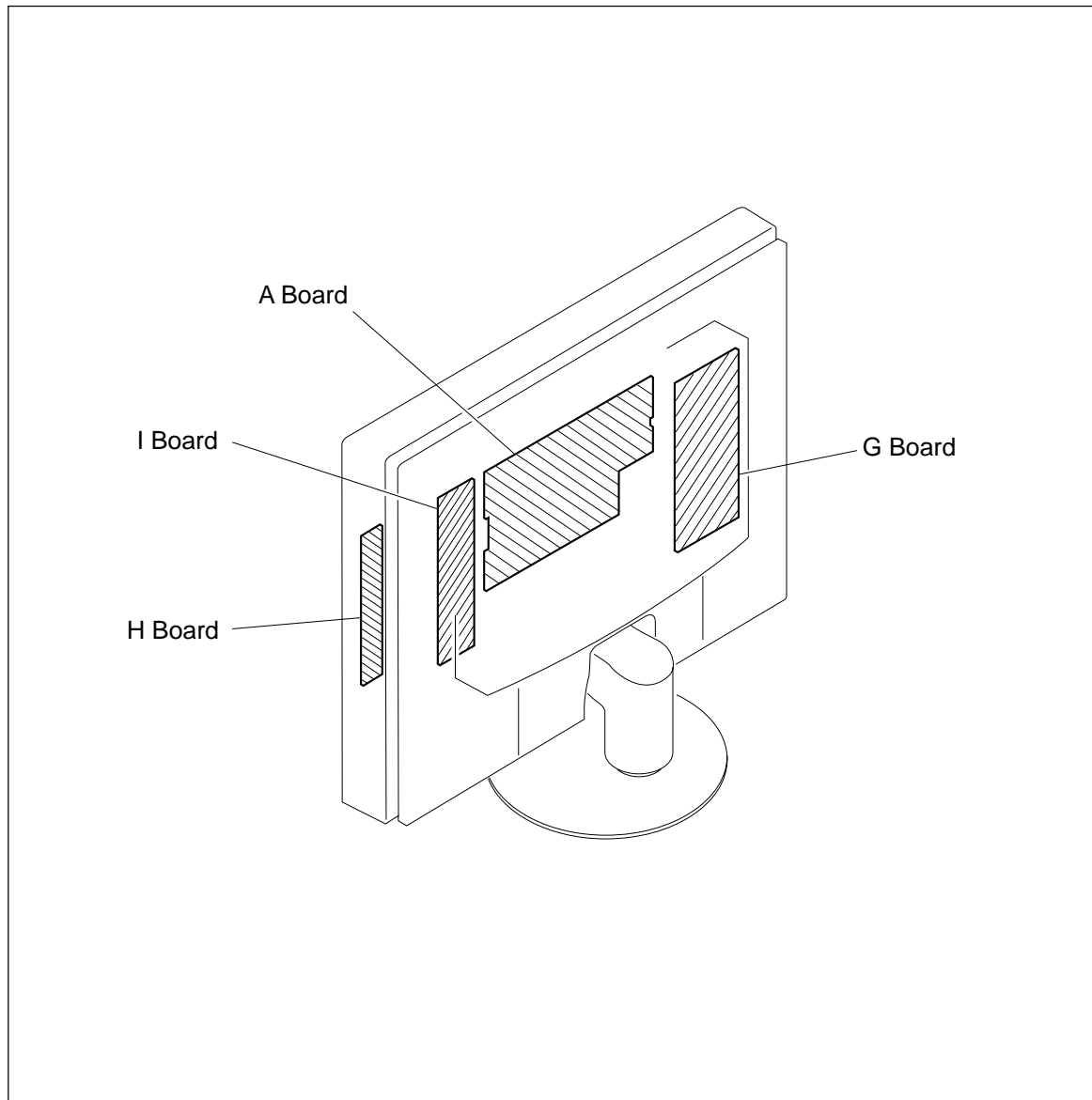

3-3. SCHEMATIC DIAGRAMS AND PRINTED WIRING BOARDS

Note:

- All capacitors are in μF unless otherwise noted. (pF: $\mu\mu\text{F}$)
Capacitors without voltage indication are all 50 V.
- Indication of resistance, which does not have one for rating electrical power, is as follows.

Pitch: 5 mm

Rating electrical power 1/4 W (CHIP : 1/10 W)

- All resistors are in ohms.
- : nonflammable resistor.
- : fusible resistor.
- Δ : internal component.
- : panel designation, and adjustment for repair.
- All variable and adjustable resistors have characteristic curve B, unless otherwise noted.
- \perp : earth-ground.
- : earth-chassis.
- When replacing the part in below table, be sure to perform the related adjustment.
- All voltages are in V.
- Readings are taken with a 10 M digital multimeter.
- Readings are taken with a color-bar signal input.
- Voltage variations may be noted due to normal production tolerances.
- * : Can not be measured.
- Circled numbers are waveform references.
- : B + bus.
- : B - bus.

- Divided circuit diagram

One sheet of A board are circuit diagram is divided into eight sheets, each having the code A- $\text{\textcircled{a}}$ to A- $\text{\textcircled{h}}$. For example, the destination $\text{\textcircled{ab1}}$ on the code A- $\text{\textcircled{a}}$ sheet is connected to $\text{\textcircled{ab1}}$ on the A- $\text{\textcircled{b}}$ sheet.

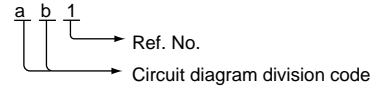

Terminal name of semiconductors in silk screen printed circuit (*)

	Device	Printed symbol	Terminal name	Circuit
①	Transistor		Collector Base Emitter	
②	Transistor		Collector Base Emitter	
③	Diode		Cathode Anode	
④	Diode		Cathode Anode (NC)	
⑤	Diode		Cathode Anode (NC)	
⑥	Diode		Common Anode Cathode	
⑦	Diode		Common Anode Cathode	
⑧	Diode		Common Anode Anode	
⑨	Diode		Common Anode Anode	
⑩	Diode		Common Cathode Cathode	
⑪	Diode		Common Cathode Cathode	
⑫	Diode		Anode Anode Cathode Anode	
⑬	Transistor (FET)		Drain Source Gate	
⑭	Transistor (FET)		Drain Source Gate	
⑮	Transistor (FET)		Source Drain Gate	
⑯	Transistor		Emitter Collector Base	
—	Discrete semiconductor			

(Chip semiconductors that are not actually used are included.)

Ver.1.6

Note: The components identified by shading and mark Δ are critical for safety. Replace only with part number specified.

Note: Les composants identifiés par un trame et une marque Δ sont critiques pour la sécurité. Ne les remplacer que par une pièce portant le numéro spécifié.

(1) Schematic Diagrams of A (a, b, c, d, e, f, g) Board

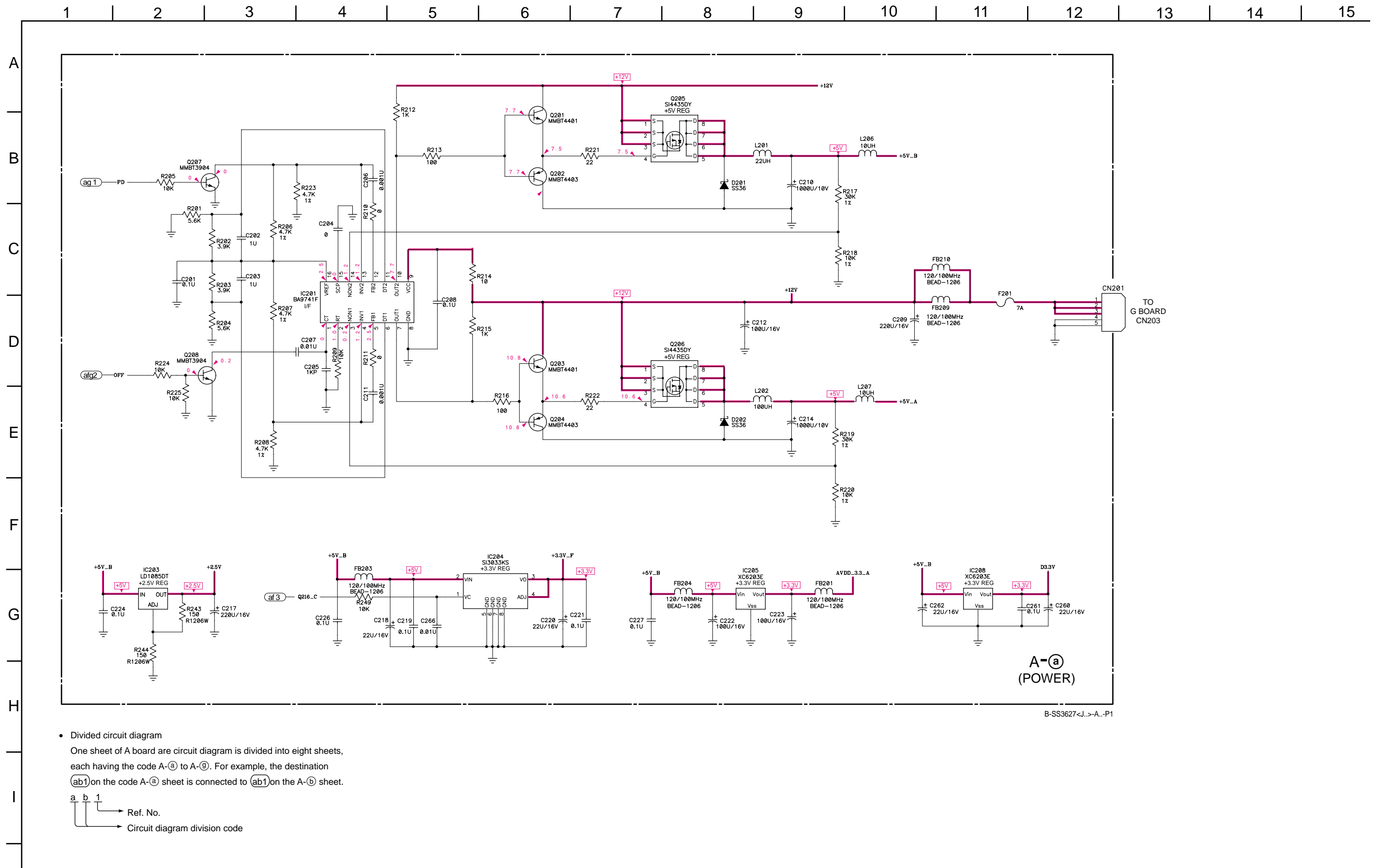

B-SS3627<J.>A.-P1

- Divided circuit diagram
One sheet of A board are circuit diagram is divided into eight sheets, each having the code A-ⓐ to A-ⓗ. For example, the destination (ab1) on the code A-ⓐ sheet is connected to (ab1) on the A-ⓗ sheet.
- a b 1
 ↳ Ref. No.
 ↳ Circuit diagram division code

1 2 3 4 5 6 7 8 9 10 11 12 13 14

A
B
C
D
E
F
G
H
I
J

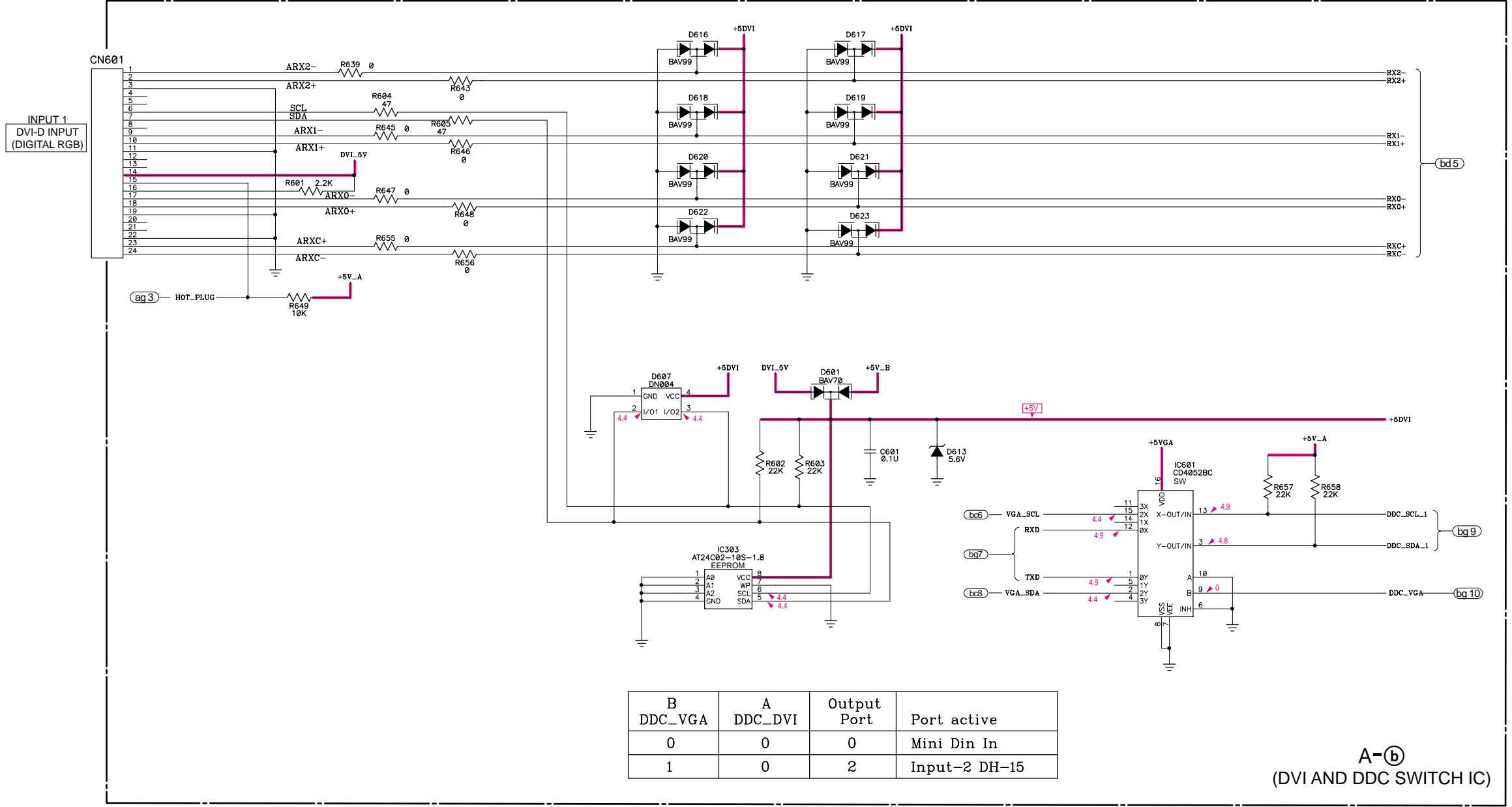

B-SS3627<J.>A.-P2

- Divided circuit diagram
One sheet of A board are circuit diagram is divided into eight sheets, each having the code A-① to A-⑧. For example, the destination (ab1) on the code A-① sheet is connected to (ab1) on the A-⑧ sheet.

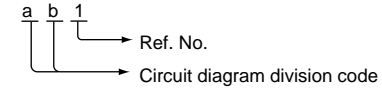

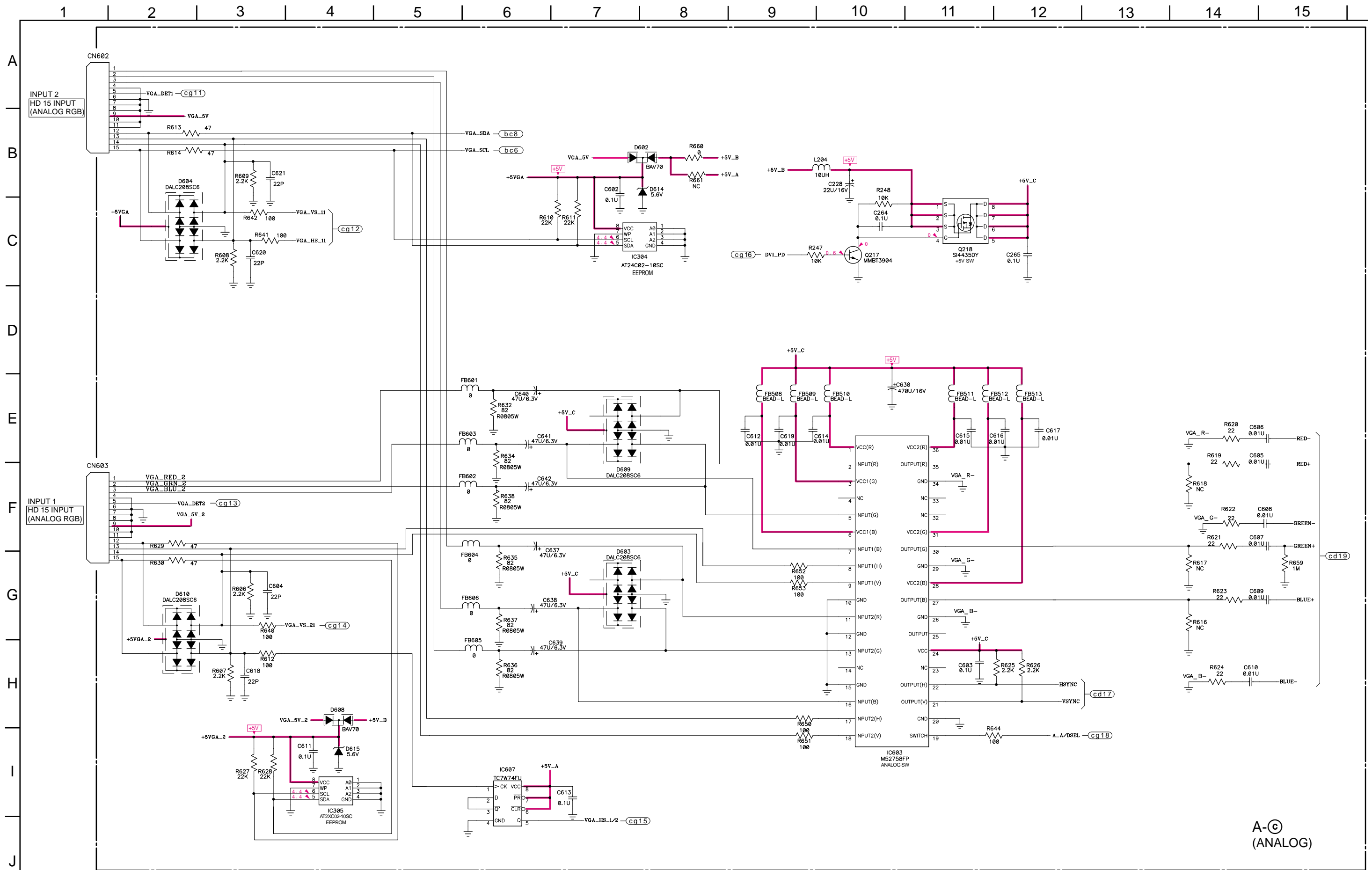

- Divided circuit diagram
- One sheet of A board are circuit diagram is divided into eight sheets, each having the code A-ⓐ to A-ⓙ. For example, the destination (ab1) on the code A-ⓐ sheet is connected to (ab1) on the A-ⓑ sheet.

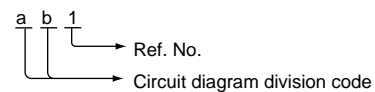

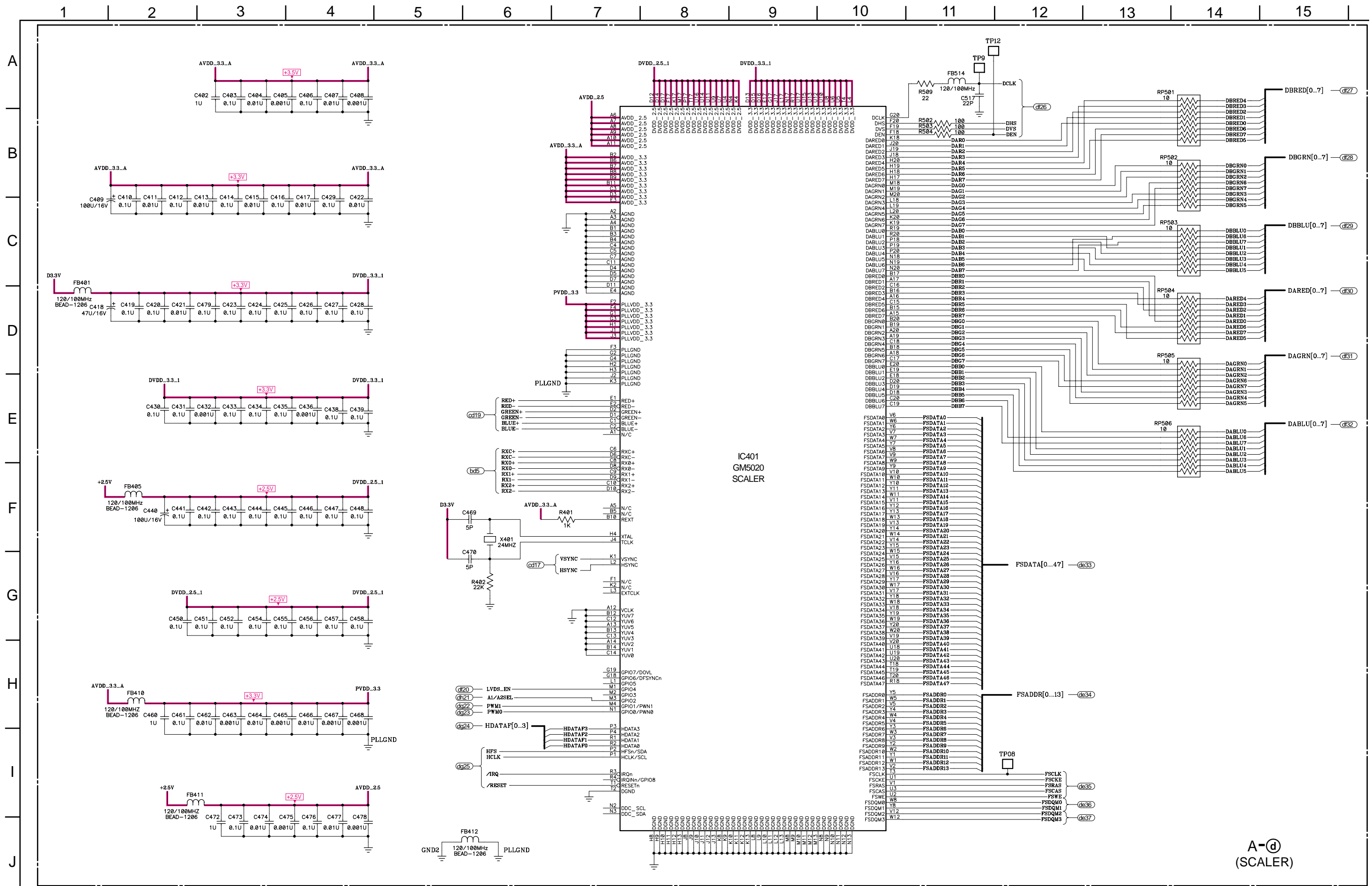

A-ⓐ
(SCALER)

• Divided circuit diagram
 One sheet of A board are circuit diagram is divided into eight sheets, each having the code A-ⓐ to A-ⓑ. For example, the destination (ab) on the code A-ⓐ sheet is connected to (ab) on the A-ⓑ sheet.

a b 1
 Ref. No.
 Circuit diagram division code

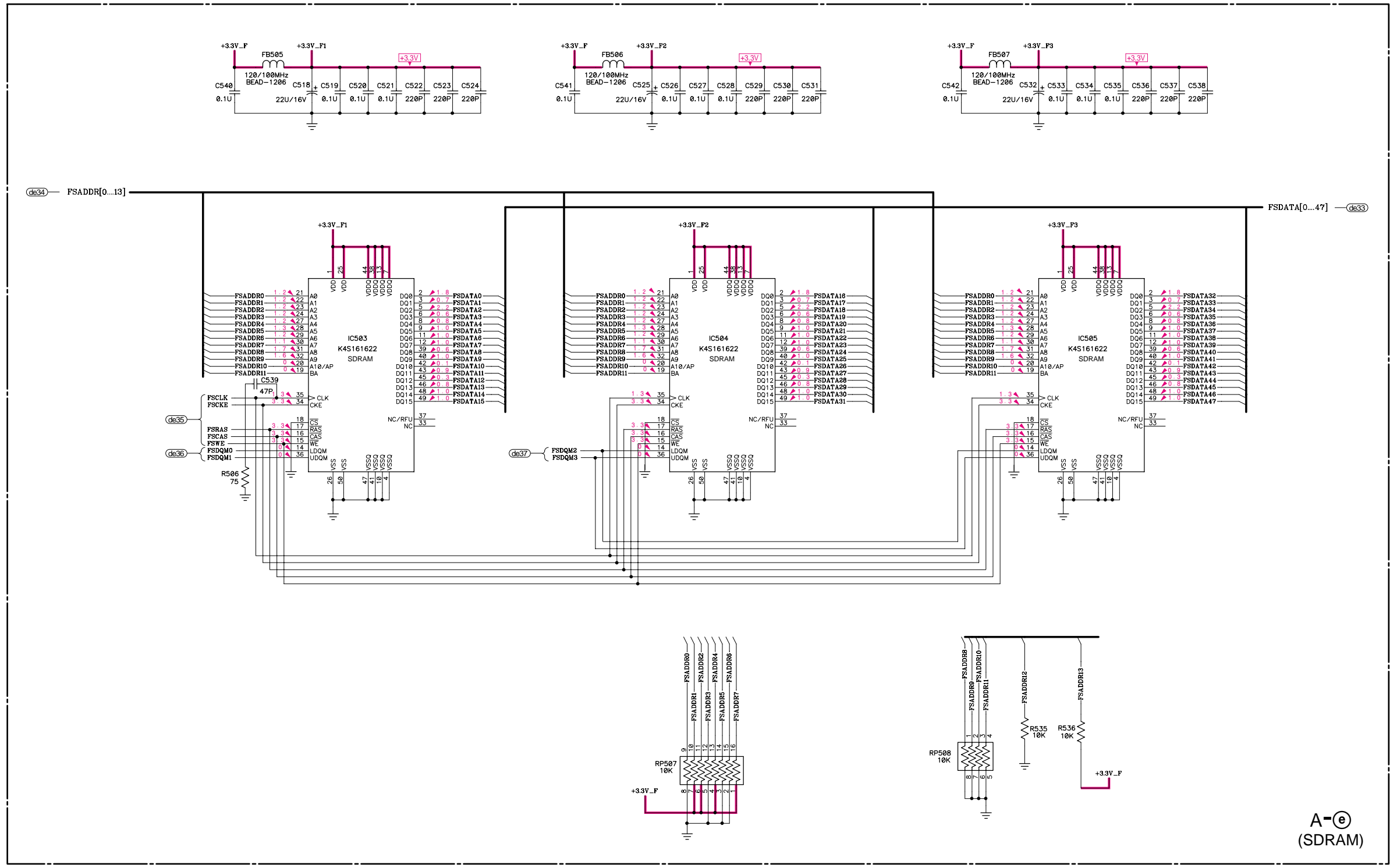

A-ⓐ
(SDRAM)

• Divided circuit diagram
 One sheet of A board are circuit diagram is divided into eight sheets, each having the code A-ⓐ to A-ⓑ. For example, the destination (ab1) on the code A-ⓐ sheet is connected to (ab1) on the A-ⓑ sheet.

a b 1
 Ref. No.
 Circuit diagram division code

B-SS3627<J...>-A..-P5

	X82,P82	X72
L205	0	X
L204	X	0

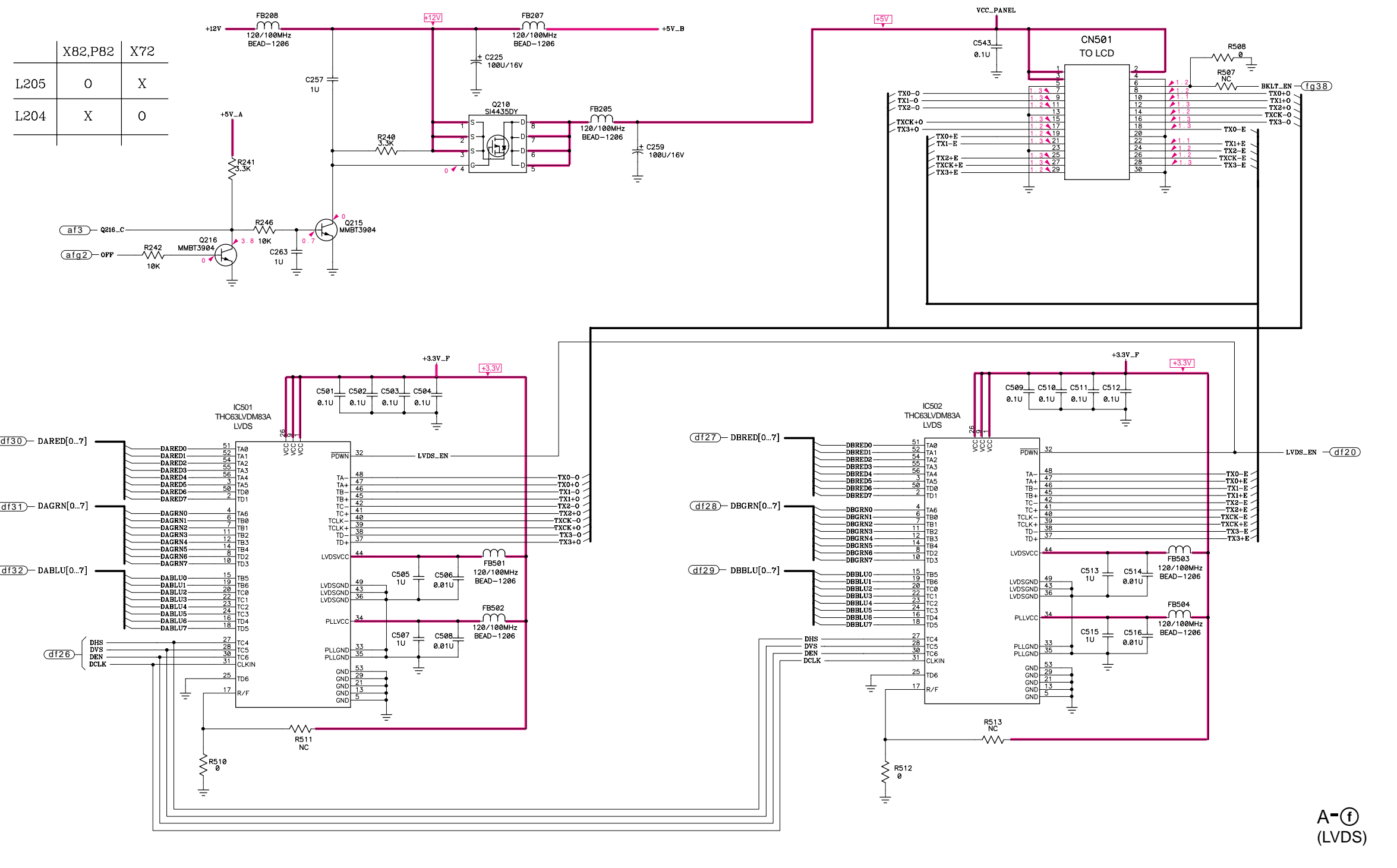

A-ⓐ (LVDS)

B-SS3627<J>A..P6

• Divided circuit diagram
 One sheet of A board are circuit diagram is divided into eight sheets, each having the code A-ⓐ to A-ⓑ. For example, the destination (ab1) on the code A-ⓐ sheet is connected to (ab1) on the A-ⓑ sheet.

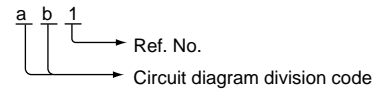

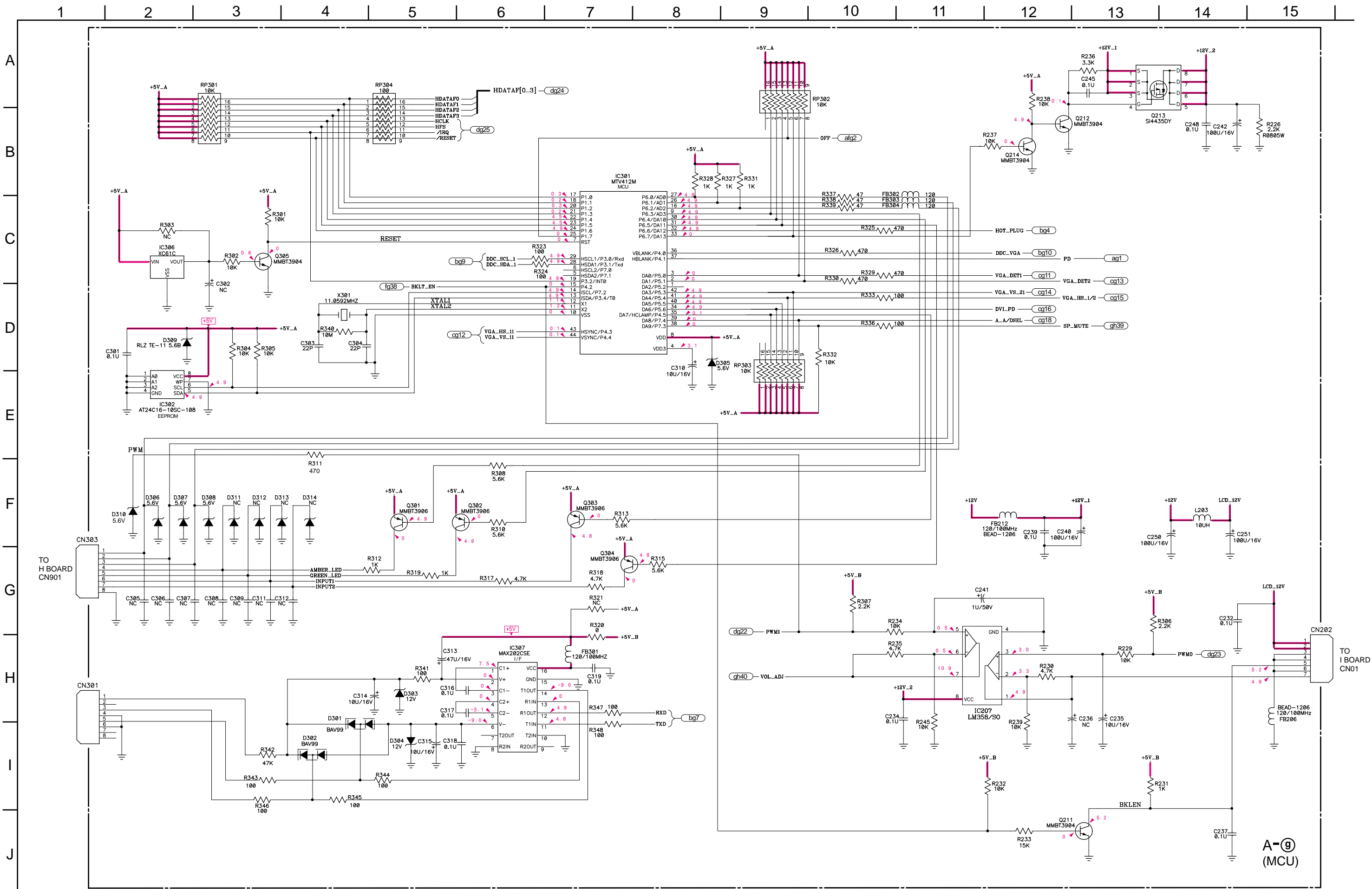

• Divided circuit diagram
 One sheet of A board circuit diagram is divided into eight sheets, each having the code A-① to A-⑧. For example, the destination (ab1) on the code A-① sheet is connected to (ab1) on the A-② sheet.

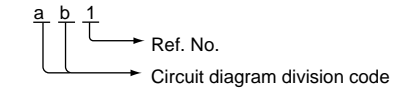

B-SS3627<J.> - A.-P7

A [MAIN CPU,SYSTEM IC,COLOR DEC,A/D CONV,3D COMB FILTER]

— A BOARD —

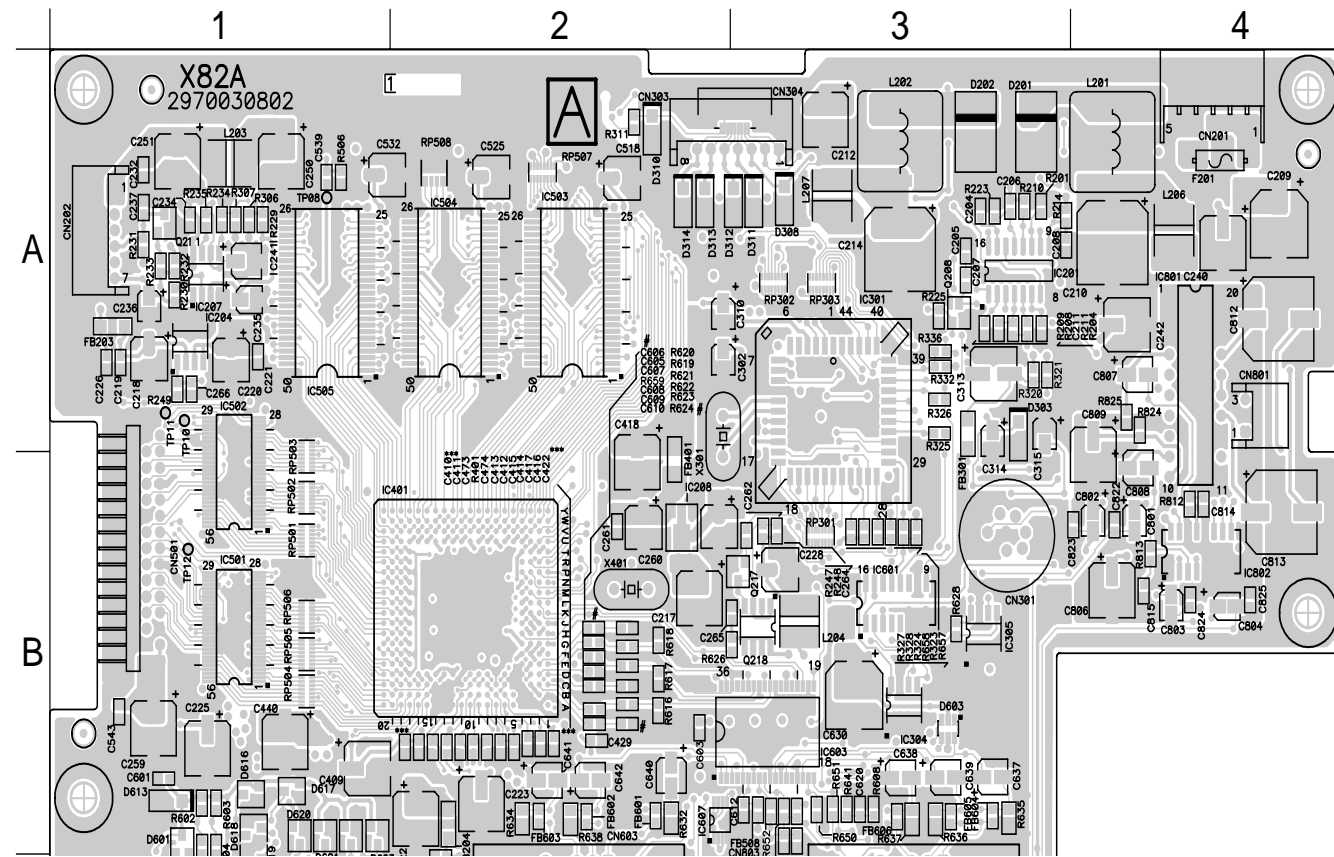

<COMPONENT SIDE>

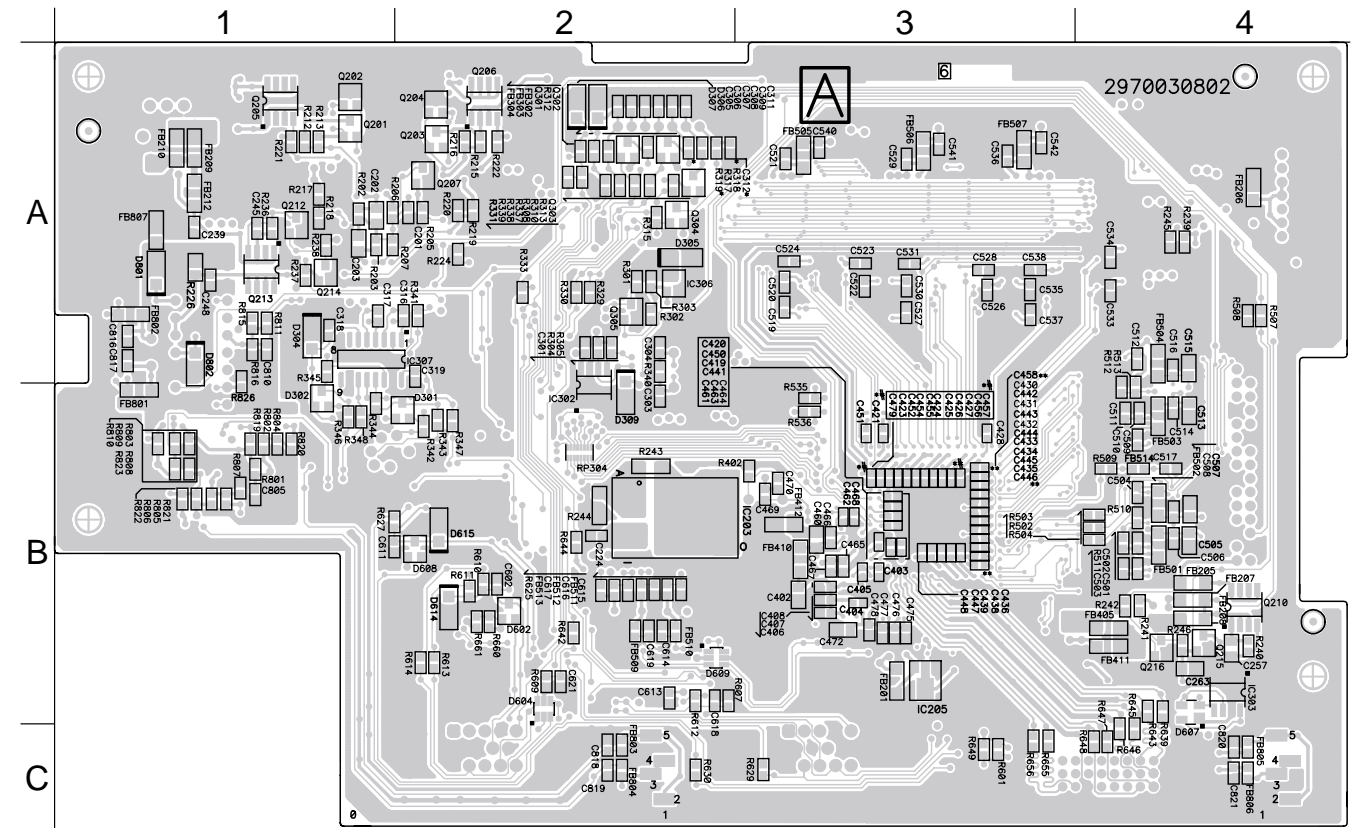

<CONDUCTOR SIDE>

A [MAIN CPU,SYSTEM IC,COLOR DEC,A/D CONV,3D COMB FILTER]

— A BOARD —

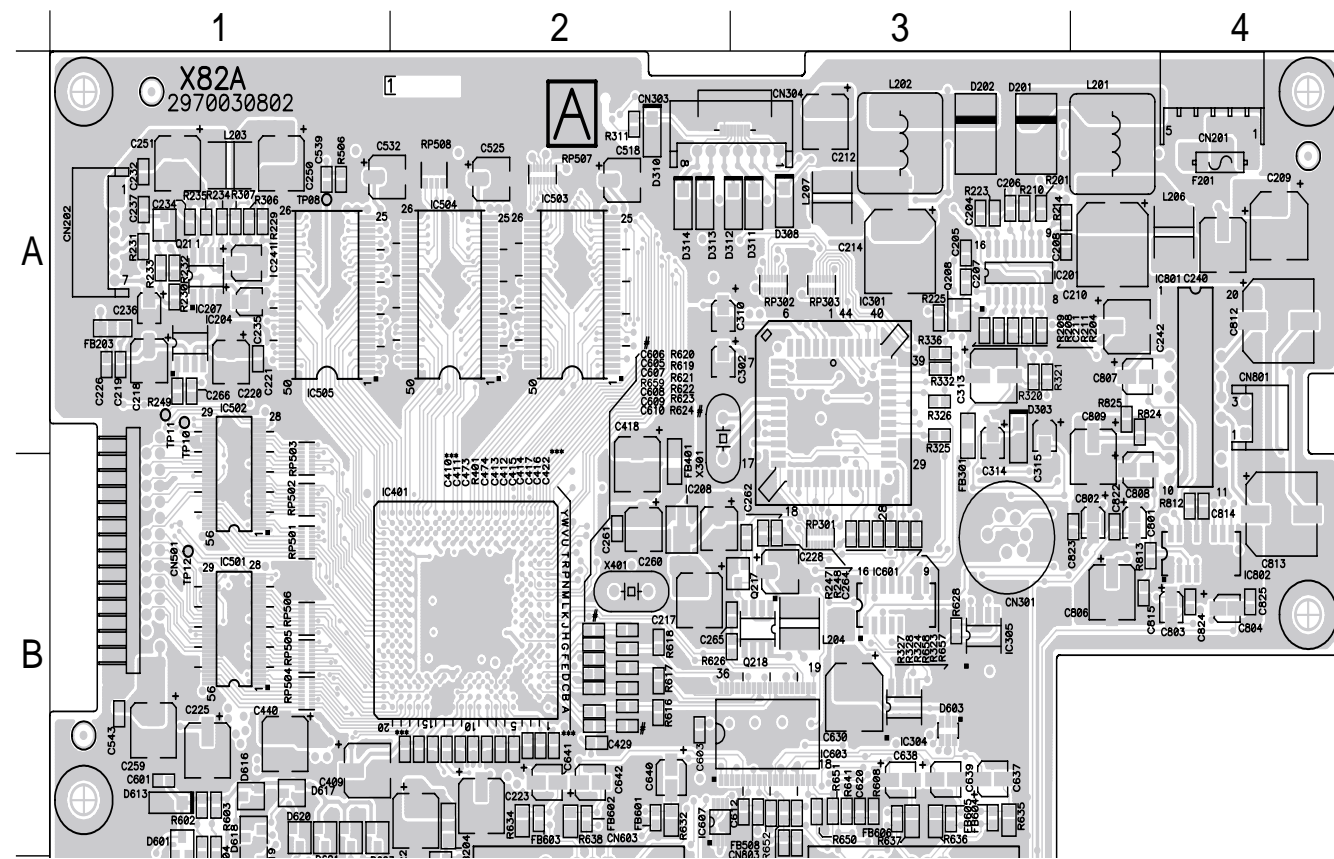

<COMPONENT SIDE>

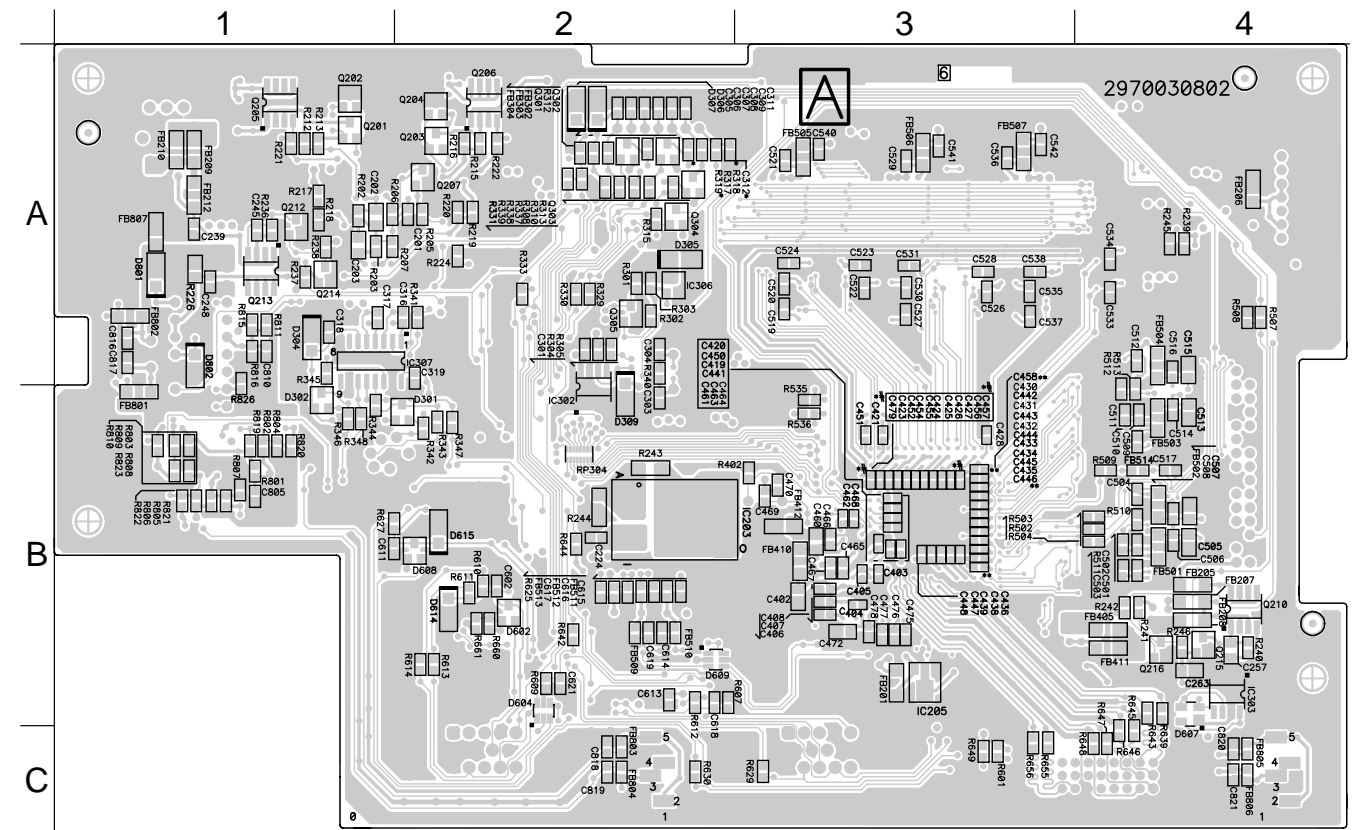

<CONDUCTOR SIDE>

(2) Schematic Diagram of H Board

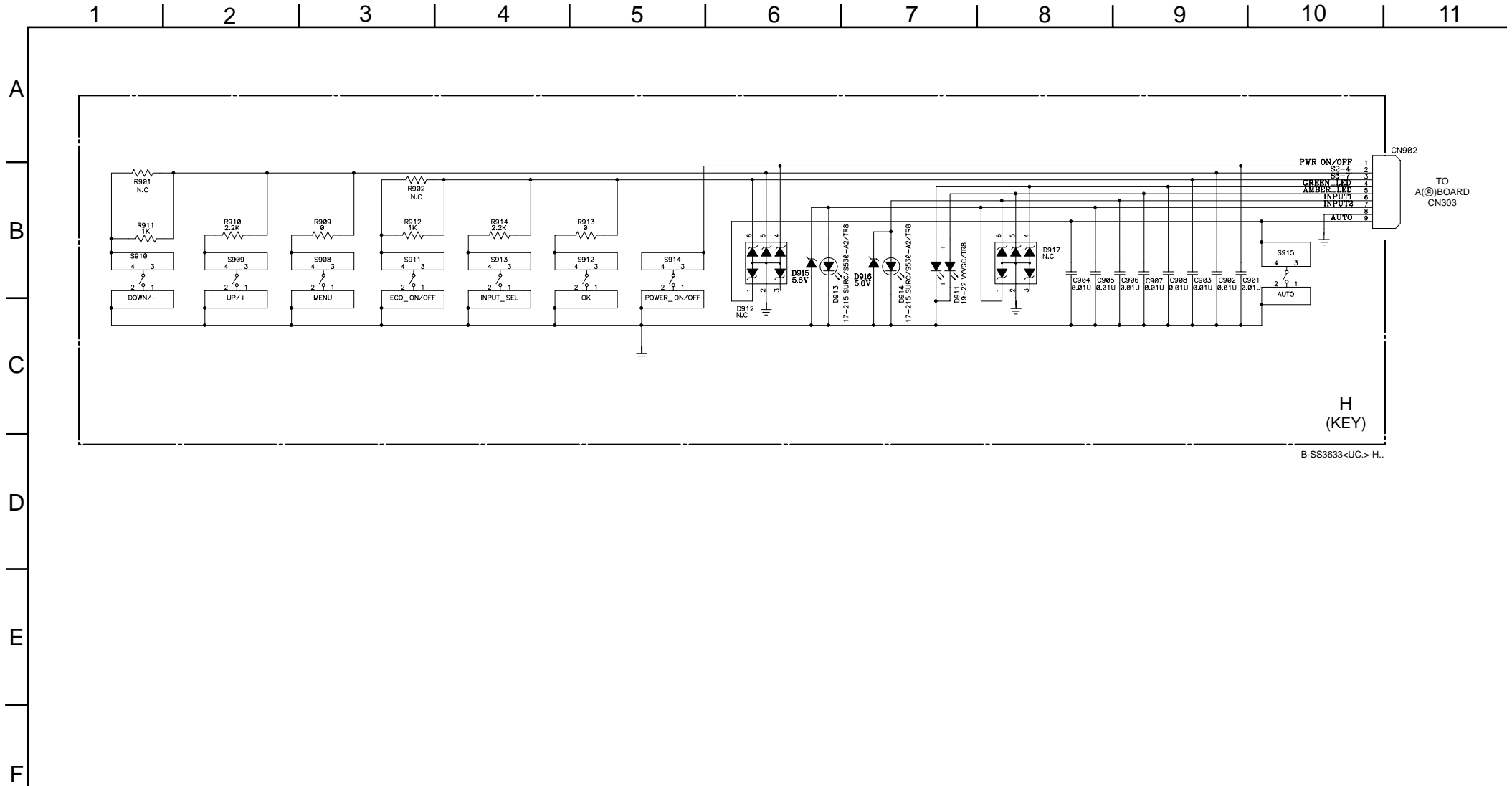

H [KEY]

— H BOARD —

<COMPONENT SIDE>

<CONDUCTOR SIDE>

(3) Schematic Diagrams of I Board

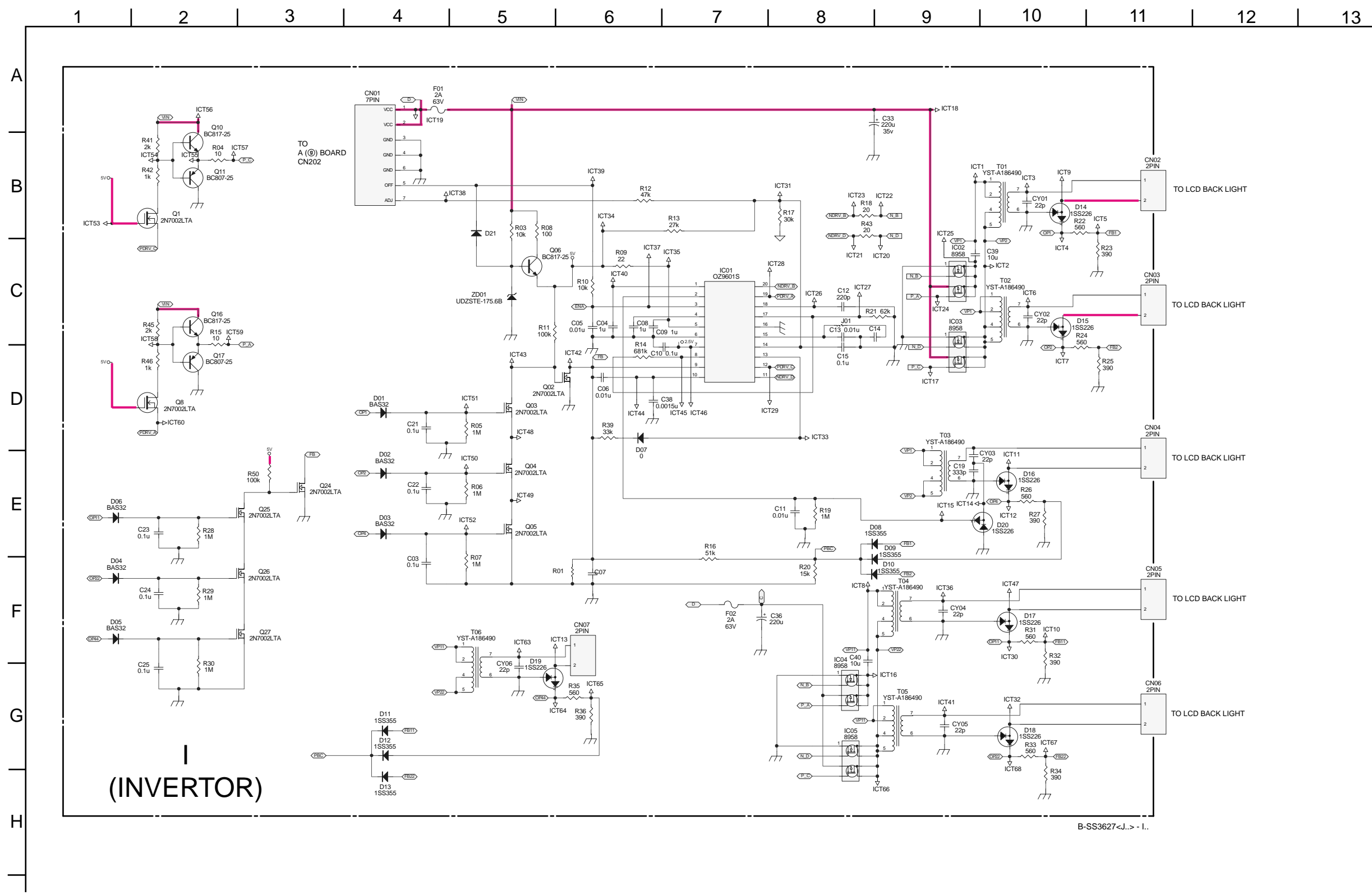

 [INVERTER]
 — I BOARD —

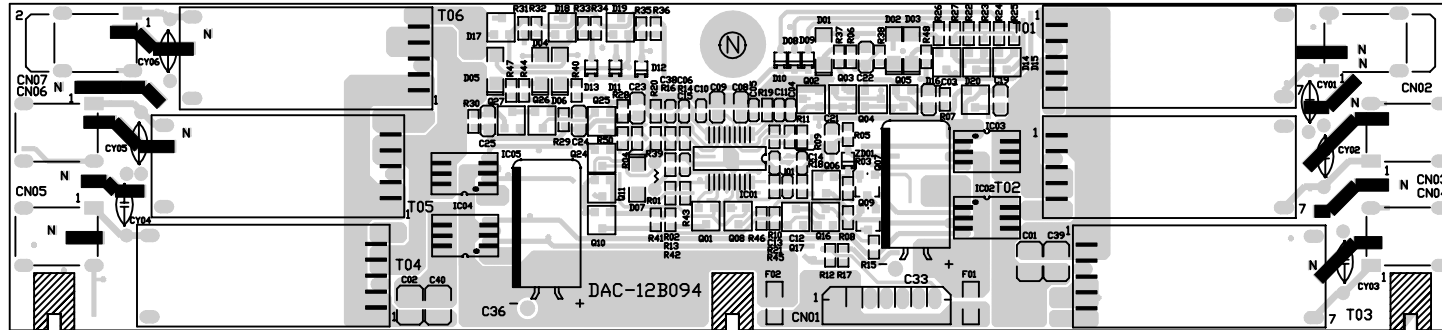

<COMPONENT SIDE>

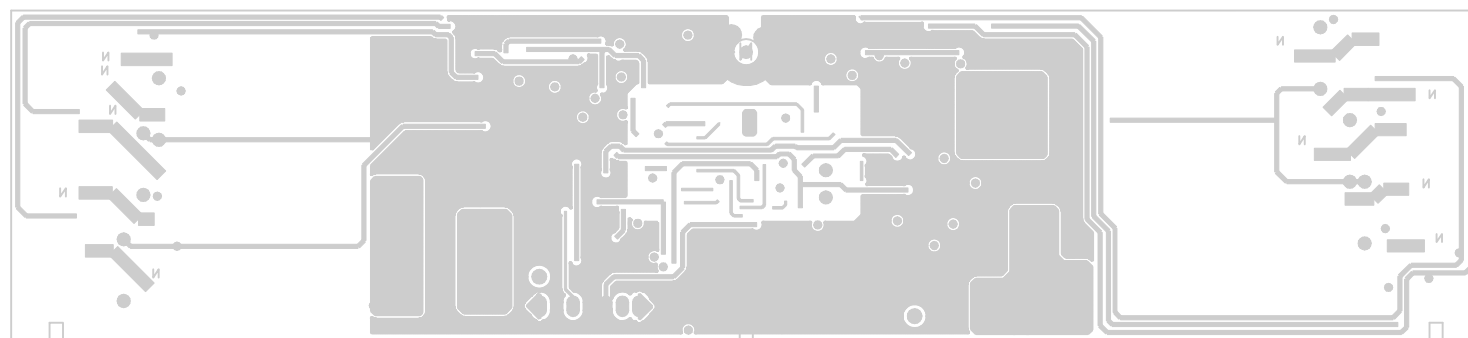

<CONDUCTOR SIDE>

(4) Schematic Diagrams of G Board

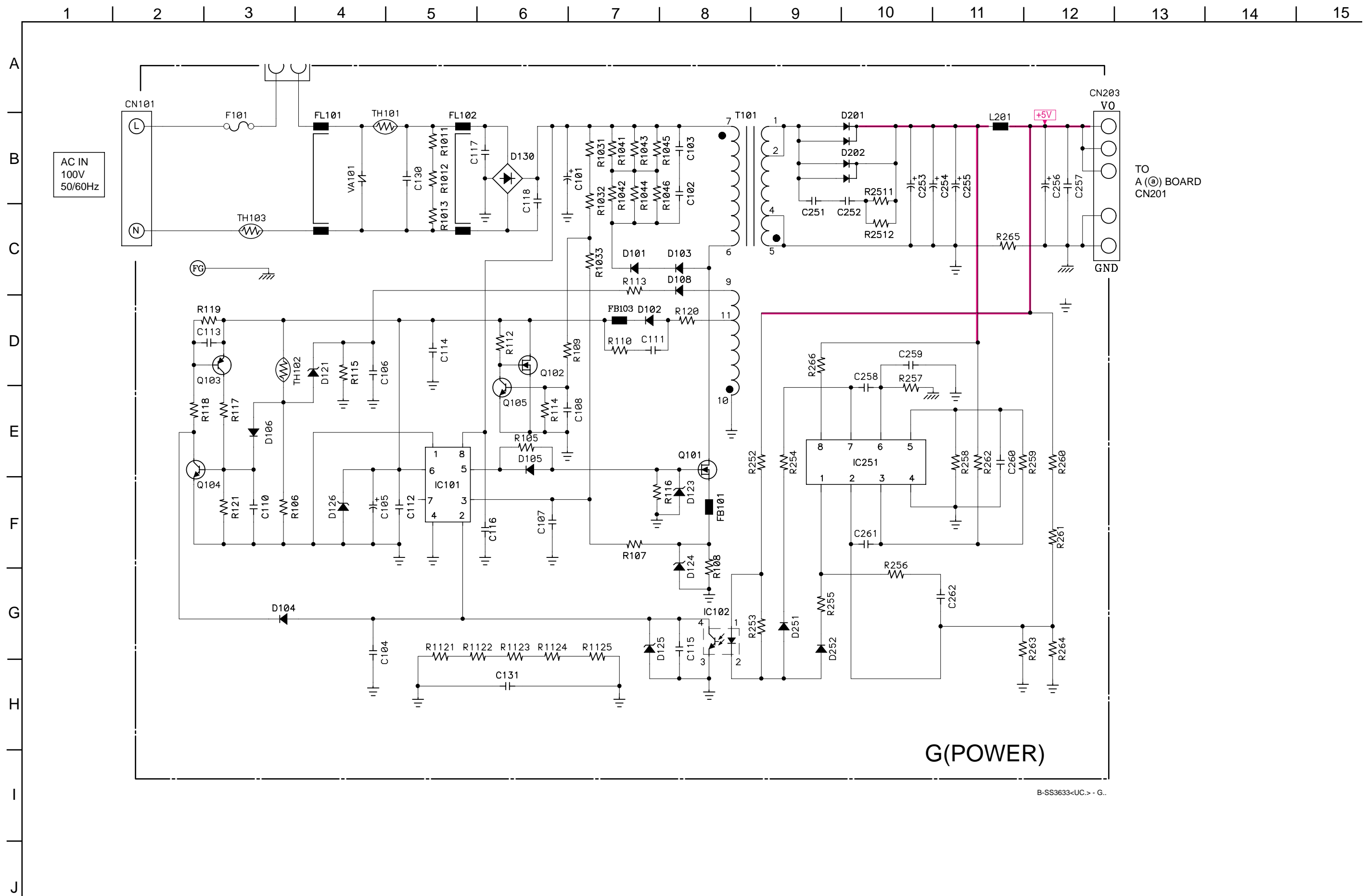

B-SS3633<UC.> - G..

G [POWER SUPPLY]

—G BOARD —

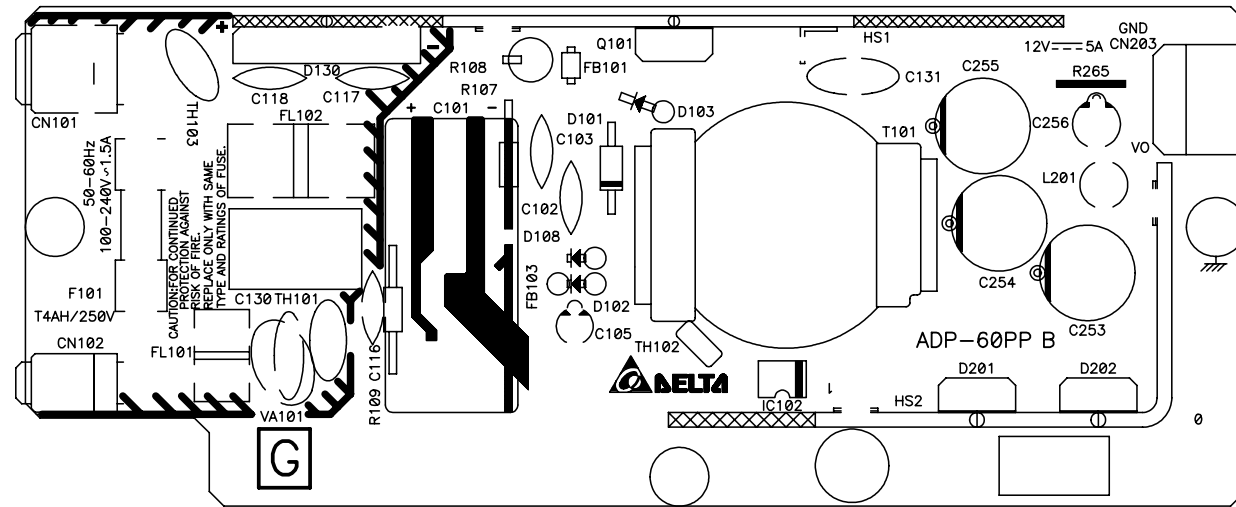

<COMPONENT SIDE>

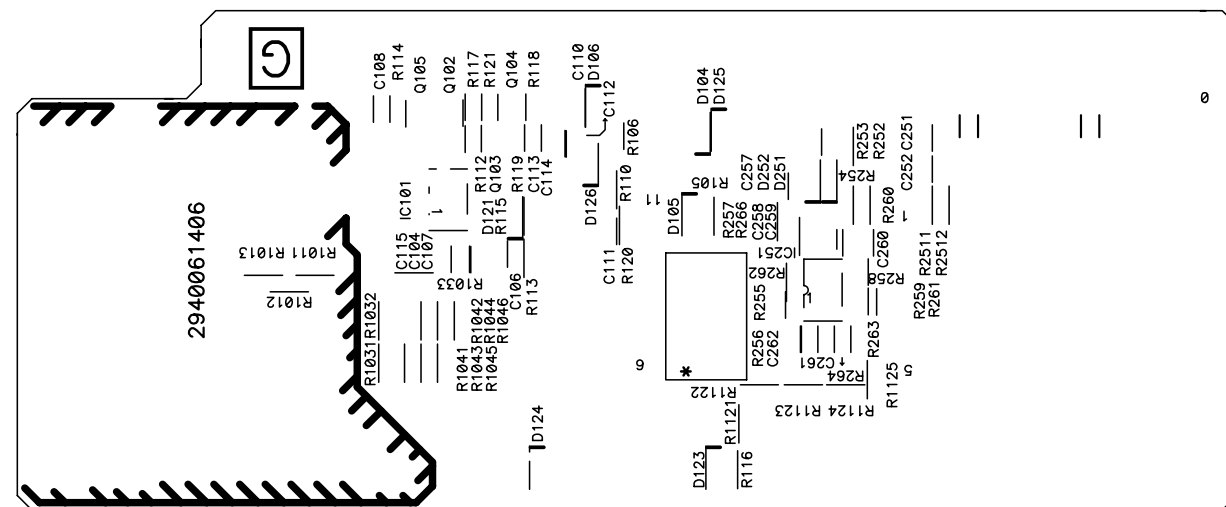

<CONDUCTOR SIDE>

SECTION 4 EXPLODED VIEWS

- Items with no part number and no description are not stocked because they are seldom required for routine service.
- The construction parts of an assembled part are indicated with a collation number in the remark column.
- Items marked " * " are not stocked since they are seldom required for routine service. Some delay should be anticipated when ordering these items.

The components identified \triangle marked are critical for safety.
Replace only with the part number specified.

Les composants identifiés par la marque \triangle sont critiques pour la sécurité.
Ne les remplacer que par une pièce portant le numéro spécifié.

4-1. CHASSIS

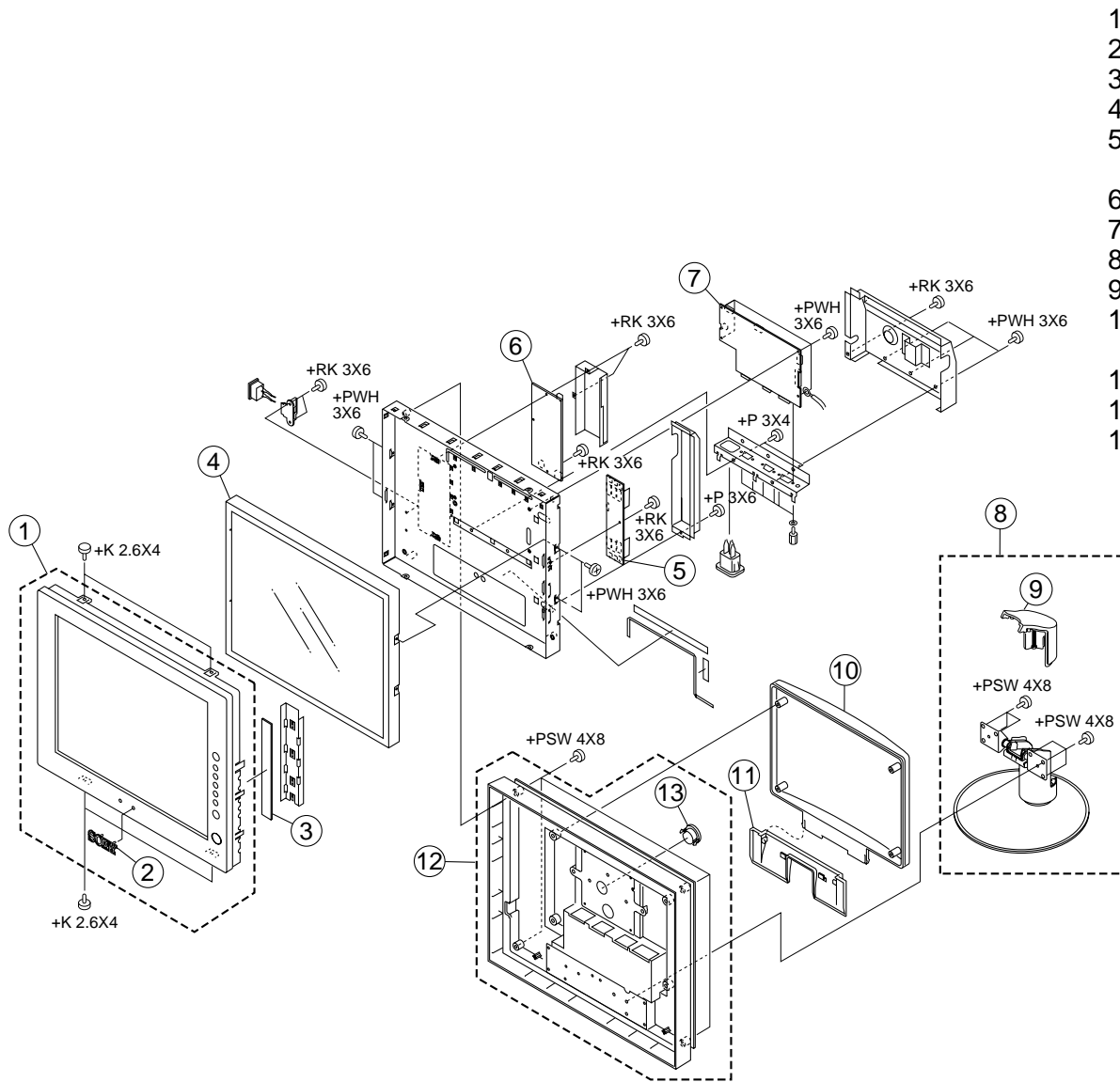

REF.NO.	PART NO.	DESCRIPTION	REMARK
1	X-4040-765-1	BEZEL ASSY	
2	3-704-176-51	EMBLEM (NO.6), SONY	
3	1-761-645-11	H BOARD, MOUNT	
4	1-804-967-11	PANEL, LCD (LM181E05)	
5	1-761-646-11	I BOARD, MOUNT	
6	1-761-615-11	G BOARD, MOUNT	
7	1-761-644-11	A BOARD, MOUNT	
8	X-4040-766-1	STAND ASSY	9
9	4-090-701-01	ARM (REAR)	
10	4-090-715-01	COVER, REAR	
11	4-090-704-01	COVER CABLE	
12	X-4040-764-1	CABINET ASSY	13
13	4-089-923-01	COVER, MINI DIN	

4-2. PACKING MATERIALS

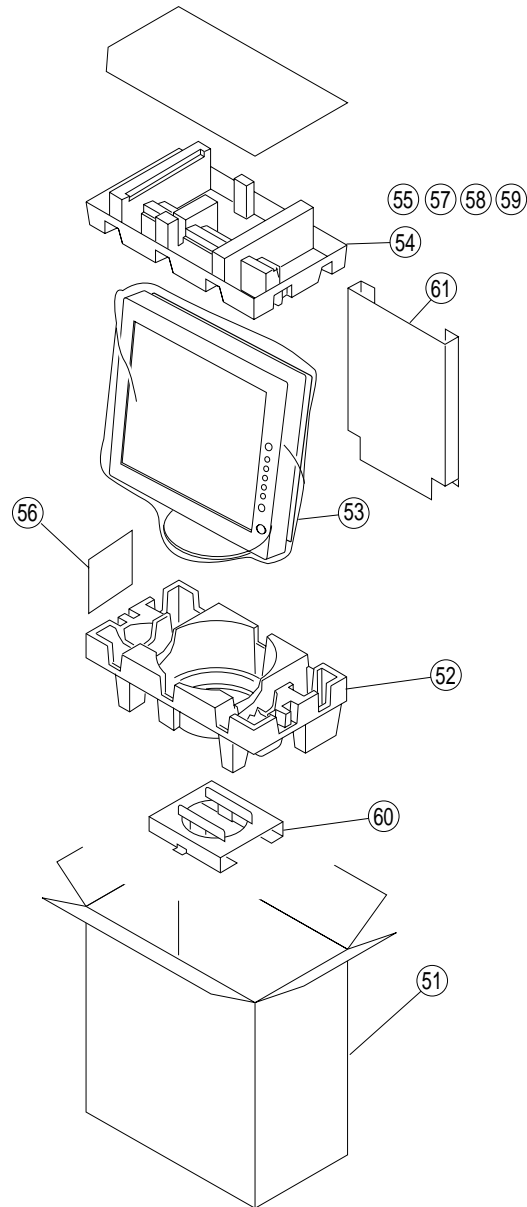

REF.NO.	PART NO.	DESCRIPTION	REMARK
51	* 4-090-725-01	INDIVIDUAL CARTON	
52	* 4-090-727-11	CUSHION (LOWER)	
53	* 4-378-262-21	BAG, PROTECTION	
54	* 4-090-726-01	CUSHION (UPPER)	
55	1-765-718-11	CORD SET, POWER	
56	1-796-496-11	DISC, CD-ROM	
57	1-824-596-11	CABLE, D-SUB	
58	1-824-598-11	CABLE, DVI-D	
59	4-090-729-11	MANUAL INSTRUCTION	
60	* 4-091-820-01	PAPER SHEET (BOTTOM)	
61	* 4-091-819-01	PAPER SHEET (BACK)	

SECTION 5

ELECTRICAL PARTS LIST

NOTE:

The components identified \triangle marked are critical for safety.
Replace only with the part number specified.

Les composants identifiés par la marque \triangle sont critiques pour la sécurité.
Ne les remplacer que par une pièce portant le numéro spécifié.

When indicating parts by reference number, please include the board name.

- All variable and adjustable resistors have characteristic curve B, unless otherwise noted.
- Items marked " * " are not stocked since they are seldom required for routine service. Some delay should be anticipated when ordering these items.

RESISTORS

- All resistors are in ohms
- F : nonflammable

No.	#	Board	Type	△/*	Ref.No.	Part No.	Description	Remarks-1	Remarks-2	Difference
1		G	DIODE		D130	8-719-510-51	DIODE SB60B			

